

GAWAPLAST
SLOVAKIA

PRODUKTOVÝ KATALOG



O NÁS



Společnost Gawaplast Slovakia, s.r.o. působí na Slovensku již více než 25 let. Byla založena v roce 1994 jako zástupce výrobce techniky pro svařování plastů. Postupem času se transformovala na obchodní společnost a rozšířila své portfolio přímých a výhradně zastoupených evropských výrobců.

V současnosti nabízíme komplexní dodávku materiálů a techniky pro stavbu vodovodů, plynovodů, kanalizací a průmyslových rozvodů.

Jedním ze světových výrobců, kterého zastupujeme na slovenském a českém trhu, je italská společnost NUPI INDUSTRIE ITALIANE S.P.A.

Začátky spolupráce našich firem sahají do roku 2003, kdy jsme se stali výhradními zástupci pro prodej HDPE tvarovek ELOFIT na slovenském trhu. Během této doby se stal ELOFIT ověřenou značkou s vybudovanou sítí spokojených zákazníků po celém Slovensku. V roce 2018 se naše výhradní zastoupení rozšířilo o český trh.

V tomto produktovém katalogu bychom vám rádi představili sortiment elektrotvarovek a tvarovek na tupo tohoto výrobce.

Neváhejte se na nás obrátit! Všichni členové našeho týmu jsou připraveni poskytnout vám prostřednictvím svých služeb a zkušeností to nejlepší možné řešení.

Gwaplast Slovakia, s.r.o.
VÁŠ SPOLEHLIVÝ PARTNER
SE ZÁRUKOU KVALITY
Ing. Kurčík Michal

GAWAPLAST
SLOVAKIA



OBSAH

POLYETYLÉNOVÉ TVAROVKY PRO TLAKOVÉ ROZVODY PLYNU, VODY A KANALIZACE.....	6
<i>TECHNICKÉ INFORMACE</i>	<i>7</i>
1. ELEKTROTVAROVKY HDPE PE100 PRO TLAKOVÉ ROZVODY PLYNU, VODY A KANALIZACE	9
<i>ELEKTROSVAROVACÍ PROCES</i>	<i>10</i>
<i>1.1.ELEKTROSPojKY.....</i>	<i>13</i>
<i>1.2.ELEKTROVÍČKA.....</i>	<i>17</i>
<i>1.3.ELEKTRO T-KUSY.....</i>	<i>18</i>
<i>1.4.ELEKTROKOLENA.....</i>	<i>19</i>
<i>1.5.ELEKTROREDUKCE.....</i>	<i>22</i>
<i>1.6.SEDLOVÉ ELEKTROTVAROVKY NAVRTÁVACÍ.....</i>	<i>23</i>
<i>1.7.SEDLOVÉ ELEKTROTVAROVKY HRDLOVÉ.....</i>	<i>32</i>
<i>1.8.SEDLOVÉ ELEKTROTVAROVKY BALONOVACÍ</i>	<i>40</i>
<i>1.9.SEDLOVÉ ELEKTROTVAROVKY OPRAVÁRENSKÉ.....</i>	<i>42</i>
2.TVAROVKY PRO SVAŘOVÁNÍ NA TUPO HDPE PE100 PRO TLAKOVÉ ROZVODY PLYNU, VODY A KANALIZACE	45
<i>2.1.TVAROVKY VSTŘIKOVANÉ</i>	<i>46</i>
<i>2.2.OTOČNÉ PŘÍRUBY.....</i>	<i>72</i>
<i>2.3.SEGMENTOVÁ KOLENA.....</i>	<i>79</i>
<i>2.4. FORMOVANÉ OBLOUKY</i>	<i>82</i>
<i>2.5.PŘECHODKY ZÁVITOVÉ PE/MOSAZ</i>	<i>89</i>
<i>2.6. ZEMNÍ PŘECHODKY</i>	<i>90</i>
3.VŠEOBECNÉ OBCHODNÍ PODMÍNKY	92
<i>VŠEOBECNÉ OBCHODNÍ PODMÍNKY, KONTAKTY.....</i>	<i>92</i>

POUŽITÁ TERMINOLOGIE A VYSVĚTLIVKY

PE	<i>Polyetylén</i>
OD, D	<i>Vnější průměr v mm</i>
DN, Dn, D _n	<i>Vnitřní průměr v mm (nominální průměr, světlost potrubí)</i>
Sp	<i>Tloušťka stěny v libovolném místě po obvodu (zaokrouhleno na 0,1 mm nahoru)</i>
s	<i>Tloušťka stěny potrubí</i>
PN	<i>Tlaková třída, maximální provozní tlak v barech (při 20°C po dobu 50 let)</i>
MRS	<i>Minimální požadovaná tloušťka stěny</i>
S	<i>Provozní tlak plyných paliv</i>
MOP	<i>Maximální operační tlak vyjádřený v barech korespondující s maximální tlakem plynu podle italského bezpečnostního koeficientu 3,25 (EU standard je ≥ 2)</i>
SDR	<i>Poměr vnějšího průměru potrubí k tloušťce stěny; SDR max – maximální možná použitelná hodnota SDR</i>
C	<i>Bezpečnostní koeficient (1,25 pro vodu, 3,25 pro plyn)</i>

LEGENDA

Gawaplast Slovakia firemní kód zboží

Kód

Minimální počet kusů v balení

Bal.

*Maximální vrtací hloubka pro navrtávací sedlo
(udávané jako minimální SDR potrubí)*

PF (min. SDR)

Pro odbočkové navrtávací sedlo určuje dimenzi vrtu. Pro hrdlové odbočkové sedlo určuje maximální použitelnou dimenzi vrtu

Max.



Voda/plyn



Plyn



Voda, kanalizace, průmysl





PRODUKTOVÝ KATALOG

POLYETYLÉNOVÉ TVAROVKY PRO TLAKOVÉ ROZVODY PLYNU, VODY A KANALIZACE

EloFIT



TECHNICKÉ INFORMACE

Polyetylenové tvarovky výrobce Nupi Industrie Italiane S.p.A. jsou schváleny pro použití v ČR (cetrifikované ITC Zlín, a.s.) a jsou v souladu s normami:

UNI EN 1555 a UNI 9736 pro tlakové rozvody topných plynů

UNI EN 12201 a UNI EN ISO 15494 pro rozvody vody

POUŽITÝ MATERIÁL POLYETYLÉN PE100 MRS 10

KOMPATIBILITA S PE potrubím, tvarovkami a PE ventily s indexem toku taveniny 190°C/5kg mezi 0,2 a 1,3 gr/10 min (PE 100, PE 80)

SVAŘOVACÍ NAPĚTÍ <= 48 V

ROZMĚR KABELOVÉ SVORKY 4 mm

CERTIFIKACE UNI ENISO 15494
UNIEN 12201-3
UNIEN 1555-3
UNI9736
STNEN 12201-1
STNEN 12201-3
STNEN 12201-5
STNEN 1555-1
STNEN 1555-3

PN /SDR/MOP

	PN	SDR	MOP
PE100	25	7,4	<=5 (10)
	20	9	<=5 (10)
	16	11	<=5 (10)
	10	17	<=3 (6)

MEZINÁRODNÍ HOMOLOGIZACE

Acea Pinerolese Industriale, A2A, AES Torino, Acsm AgamMonza, Amap Palermo, Iren Genova, Iren Parma, Aps Padova, Enel Gas, ToscanaEnergia, Gas de France, Gas Natural, Intesa Siena, G6 Rete Gas, Eni Italgas, Gruppo Hera, Enel Gas, Eni Napoletana Gas, Nigc, Gruppo Hera

Dvgw (Germania)
Ovgw (Austria)
NF (Francia)
Kiwa (Olanda)

Istituto Italiano dei Plastici (Italia)
Svbw (Svizzera)
Sonelgaz (Algeria)
Powergas (Singapore)

DS certifi cering (Danimarca)
Watermark (Australia)
Kitemark (Regno Unito)
E.ON(Germania)

HYGIENICKÝ CERTIFIKÁT

CERTIFIKÁT MINISTERSTVA ZDRAVOTNICTVÍ PRO ROZVODY VODY M.D...174 (ITÁLIE)



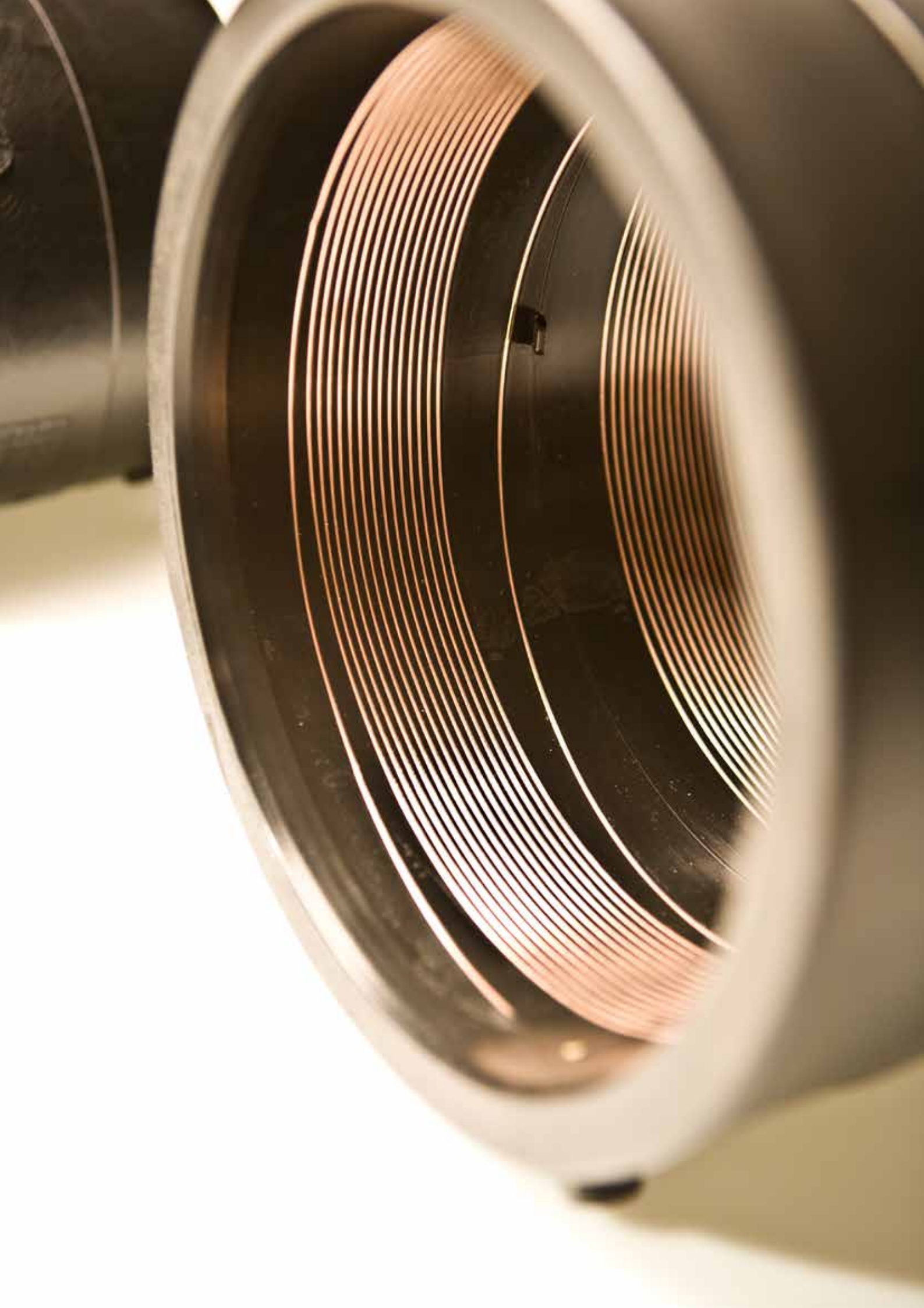



1



EloFIT

- ELEKTROTVAROVKY HDPE PE100 PRO ROZVODY PLYNU,
VODY A KANALIZACE



ELEKTROVAŘOVACÍ PROCES

Systém ELOFIT je založen na elektrosvařovacím procesu.

Uvnitř každé elektrovarovky je navinutá topná spirála, která je propojená s vnějšími kabelovými konektory.

Po zapojení topnou spirálou protéká elektrický proud, který vytváří teplo potřebné k tavení polyetylénu.

Elektrina je vedena přímo mezi povrchy tvarovky a potrubí, což způsobuje tavení obou částí.

Po vychladnutí je spoj homogenní, pevný, bezpečný a spolehlivý.

Co je elektrosvařovací proces?

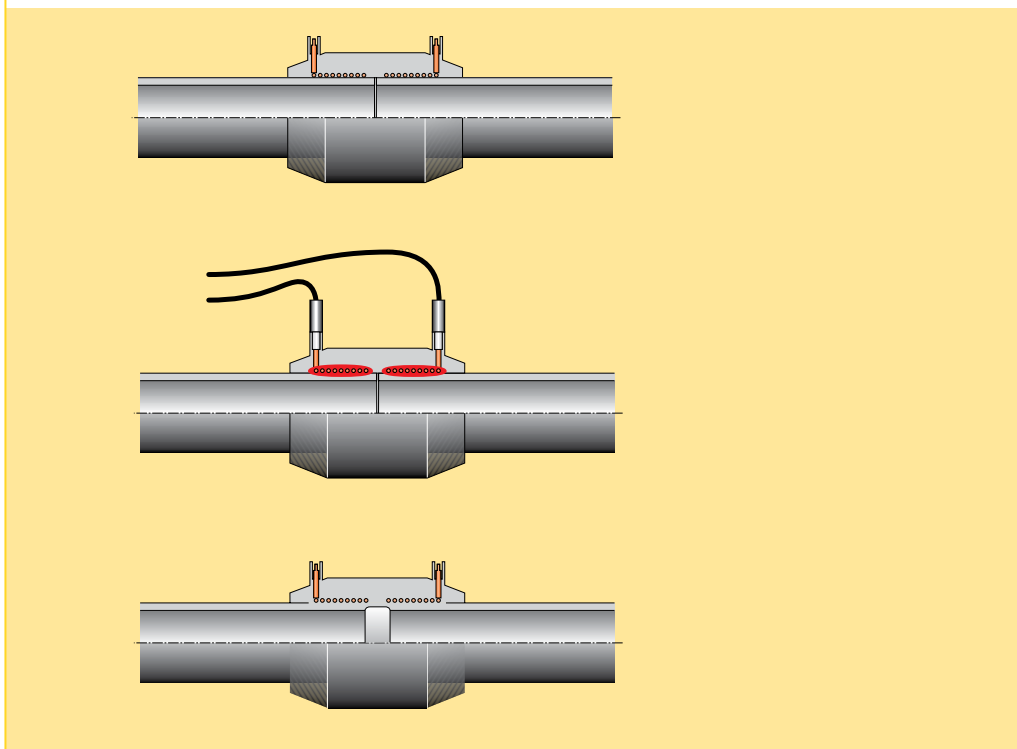

JAK SPRÁVNĚ NAČÍST ČÁROVÝ KÓD? PRACOVNÍ POSTUP

Svařovací čárový kód (v souladu s normou ISO 13956)

Naskenujte čárový kód pomocí čtečky čárových kódů nebo zadejte svařovací parametry času a napětí uvedené na čárovém kódu.

Svařovací proces můžete provádět pomocí automatické svařovací techniky (snímačem čárových kódů) nebo pomocí manuální svařovací techniky.

V případě automatického svařování, po načtení čárového kódu, vždy zkontrolujte parametry času a napětí uvedené na displeji svářečky.

V případě manuálního svařování zadejte parametry času a napětí uvedené na čárovém kódu.

Příbalová etiketa

Pokud svářečka neprovádí kompenzaci času svařování podle okolní teploty, použijte parametry uvedené na příbalové etiketě.



SVAŘOVACÍ ČÁROVÝ KÓD

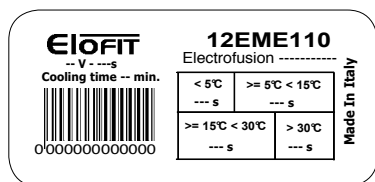

PŘÍBALOVÁ ETIKETA

Čárový kód předehřevu (pokud je uveden žlutý čárový kód)

Slouží k eliminaci případné ovality potrubí a mezery mezi tvarovkou a potrubím.

V případě, že je tento žlutý čárový kód předehřevu na tvarovce uvedený, vykonajte tento svar vždy jako první, ještě před zahájením řádného svařovacího procesu. Tento svar je možné opakovat až do dosažení optimálního stavu pro řádný svar.

Dvojitý čárový kód

V případě dvojitého čárového kódu musí být svařování provedeno naskenováním prvního čárového kódu (první svařování) a okamžitě poté naskenováním druhého čárového kódu (druhé svařování), bez doby chladnutí mezi svary.



POUŽÍVEJTE VÝHRADNĚ PRAVIDELNĚ SERVISOVANOU SVAŘOVACÍ TECHNIKU URČENOU NA SVAŘOVÁNÍ ELEKTROTVAROVEK A POSTUPOJTE PODLE INSTRUKCÍ K DOSAŽENÍ SPOLEHLIVÉHO SVARU.



CHRAŇTE POTRUBÍ PŘED JAKÝMKOLIV POHYBEM A PNUTÍM PŘI SVAŘOVACÍM PROCESU A PŘI CHLADNUTÍ SVARU!



BĚHEM SVAŘOVÁNÍ DODRŽUJTE BEZPEČNOU VZDÁLENOST!



ČÁROVÝ KÓD PŘEDEHŘEVU (POKUD JE UVEDEN ŽLUTÝ ČÁROVÝ KÓD)

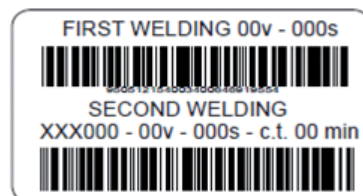

DVOJITÝ ČÁROVÝ KÓD



PRACOVNÍ POSTUP SVAŘOVÁNÍ ELEKTROTVAROVKAMI



Pečlivá příprava materiálu před samotným svařováním je jedním z nejdůležitějších kroků k dosažení bezpečného svaru! Potrubí řežte vždy kolmo rezačkou určenou na potrubí.



Oškrábejte povrch potrubí souměrně pomocí škrabky nebo loupacího zařízení po celé svařovací zóně a minimálně 1cm za koncem elektrotvarovky po nasazení.



Odstraňte z potrubí, tvarovky a místa svaru všechny nečistoty jako je bláto, prach, mastnota, aj. Počkejte dokud není čištěné místo úplně suché. Používejte jen tangit popř. jiný izopropylalkohol a bezvláknitý papír.



Označte příslušným značkovačem svařovací délku na potrubí (u objímek s dorazem je to hloubka zasunutí, u objímek bez dorazu je to rozměr mezi hranou a středem objímky).



Zasuňte potrubí do tvarovky až po označenou vzdálenost a zajistěte ho před pohybem.



Připojte svařovací kabely k tvarovkovým konektorům, naskenujte čárový kód čtečkou na čárové kódy a postupujte podle návodu: **Jak správně načíst čárový kód.**



Před zahájením samotného svařovacího cyklu vždy zkontrolujte svařovací parametry.



Po ukončení svařovacího cyklu odpojte kabely a dodržte dobu chlazení vyznačenou na čárovém kódu.

Pozrite si video návod na: 



ELECTROFUSION (EN)

ELEKTROSPÖJKY



ELEKTROSPÖJKA SDR11 PN16 EME

(*) SDR max: Ø 20, 25, 32 svařitelné s SDR 11- 9 - 7,4
 Od Ø 40 do Ø 800 svařitelné s SDR 17,6 - 17 - 13,6 - 11 - 9 - 7,4
 Od Ø 225 čárový kód s předehřevem
 Do Ø 315 s odnímatelnou zarážkou, větší Ø bez zarážky

PE100 SDR11 PN16

slevová skupina "C"

Kód	Typ	Ø	SDR max*	Bal.	Váha kg/ks	Dn	D	D2	L1	L	H	Cena CZK/ks
12EME020	A	20	11	60	0,055	20	33	-	34	70	53	70,00
12EME025	A	25	11	50	0,062	25	36	-	34	70	57	75,90
12EME032	A	32	11	40	0,079	32	46	-	34	70	65	82,40
12EME040	A	40	17,6	30	0,117	40	55	-	41	85	75	88,90
12EME050	A	50	17,6	40	0,155	50	67	-	42	87	86	133,70
12EME063	A	63	17,6	30	0,227	63	77	-	47	97	100	140,20
12EME075	A	75	17,6	24	0,366	75	98	-	61	125	114	196,60
12EME090	A	90	17,6	32	0,531	90	113	-	72	146	130	260,30
12EME110	A	110	17,6	22	0,677	110	136	-	76	155	144	310,80
12EME125	A	125	17,6	16	1,019	125	156	-	82	166	168	431,50
12EME140	A	140	17,6	30	1,187	140	168	-	84	170	181	507,90
12EME160	A	160	17,6	24	1,533	160	191	-	87	175	201	571,70
12EME180	A	180	17,6	18	1,994	180	215	-	88	177	224	857,60
12EME200	A	200	17,6	14	2,243	200	236	-	92	185	243	1 016,60
12EME225	A	225	17,6	48	3,813	225	272	-	104	212	274	1 396,80
12EME250	A	250	17,6	22	4,390	250	296	-	106	212	300	2 223,30
12EME280	A	280	17,6	12	8,750	280	355	-	110	220	338	2 667,20
12EME315	A	315	17,6	20	11,700	315	372,5	-	120	240	373	3 112,20
12EME355	B	355	17,6	6	16,667	355	450	-	-	260	-	5 715,10
12EME400	B	400	17,6	9	21,133	400	500	-	-	290	-	6 668,00
12EME450	B	450	17,6	4	35,150	450	560	-	-	340	-	13 970,20
12EME500	B	500	17,6	3	34,250	500	612	-	-	360	-	16 098,20
12EME560	C	560	17,6	3	50,667	560	-	710	-	400	-	29 065,30
12EME630	C	630	17,6	2	76,500	630	-	800	-	440	-	42 569,80
12EME710	C	710	17,6	1	91,400	710	-	900	-	480	-	57 249,10
12EME800	C	800	17,6	1	109,000	800	-	1000	-	500	-	82 203,30

ELEKTROSPÖJKY

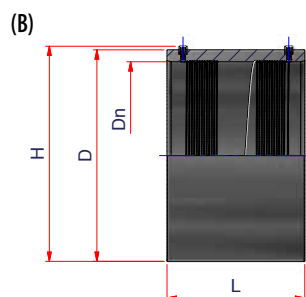
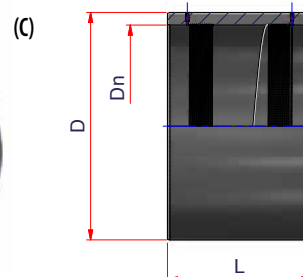
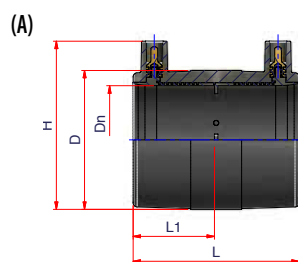

ELEKTROSPÖJKA DME

(*) SDR max: od \varnothing 90 do \varnothing 200 svařitelné s SDR 17,6 - 17 - 13,6 - 11

(*) SDR max: od \varnothing 225 do \varnothing 900 svařitelné

s SDR 21 - 17,6 - 17 - 13,6 - 11

Od \varnothing 225 čárový kód s předehřevem

Do \varnothing 315 s odnímatelnou zarážkou, větší \varnothing bez zarážky

(°) Dvojitě vinutí

PE100 SDR17 PN10

slevová skupina "C"

Kód	Typ	\varnothing	SDR max*	Bal.	Váha kg/ks	Dn	D	L1	L	H	Cena CZK/ks
12DME090	A	90	17,6	32	0,500	90	113	72	146	130	279,00
12DME110	A	110	17,6	22	0,709	110	136	76,5	155	144	280,30
12DME125	A	125	17,6	16	1,050	125	156	82	166	168	388,50
12DME140	A	140	17,6	30	1,173	140	168	84	170	181	457,40
12DME160	A	160	17,6	24	1,533	160	191	87	175	201	514,40
12DME180	A	180	17,6	18	2,067	180	215	88	177	224	771,10
12DME200	A	200	17,6	14	2,214	200	236	92	185	243	914,30
12DME225	A	225	21	52	2,337	225	272	104	212	274	1 270,40
12DME250	A	250	21	22	2,564	250	296	106	212	300	1 849,60
12DME280	A	280	21	16	4,294	280	335	110	220	338	2 159,10
12DME315	A	315	21	24	5,475	315	373	120	240	373	2 349,20
12DME355	B	355	21	10	8,700	355	400	-	260	405	5 080,10
12DME400	B	400	21	6	11,083	400	450	-	290	455	6 032,90
12DME450	B	450	21	4	16,250	450	500	-	340	505	8 890,20
12DME500	C	500	21	4	21,750	500	560	-	360	-	9 842,60
12DME560	C	560	21	3	30,000	560	630	-	400	-	16 193,50
12DME630	C	630	21	3	40,667	630	710	-	440	-	20 697,80
12DME710	C	710	21	2	56,500	710	800	-	500	-	41 102,30
12DME800	C	800	21	1	68,000	800	900	-	500	-	45 519,80
12DME900(°)	C	900	21	1	75,000	900	1000	-	540	-	102 753,60

ELEKTROSPÖJKY

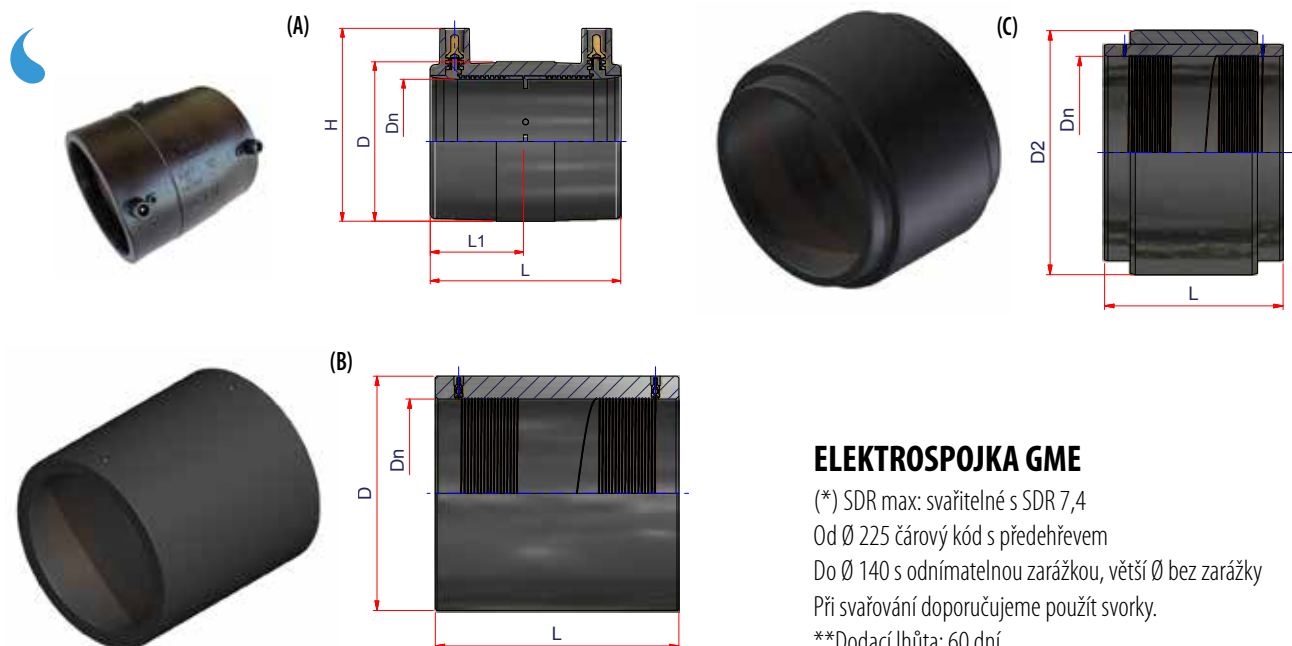

ELEKTROSPÖJKA GME

(*) SDR max: svařitelné s SDR 7,4

Od Ø 225 čárový kód s předehřevem

Do Ø 140 s odnímatelnou zarážkou, větší Ø bez zarážky

Při svařování doporučujeme použít svorky.

**Dodací lhůta: 60 dní

PE100 SDR7,4 PN25

slevová skupina "C"

Kód	Typ	Ø	SDR max*	Váha kg/ks	Dn	D	D2	L1	L	H	Cena CZK/ks
12GME020	A	20	7,4	0,055	20	33	-	34	70	53	150,80
12GME025	A	25	7,4	0,062	25	36	-	34	70	57	150,80
12GME032	A	32	7,4	0,075	32	46	-	34	70	65	169,70
12GME040	A	40	7,4	0,115	40	55	-	41	85	75	188,30
12GME050	A	50	7,4	0,158	50	67	-	42	87	86	282,60
12GME063	A	63	7,4	0,231	63	83	-	47	97	100	339,60
12GME075	A	75	7,4	0,358	75	98	-	61	125	114	433,90
12GME090	A	90	7,4	0,713	90	113	-	72	146	130	794,10
12GME110	A	110	7,4	0,677	110	136	-	76,5	155	144	988,90
12GME125	A	125	7,4	1,667	125	156	-	82	166	168	1 387,50
12GME140	A	140	7,4	2,177	140	168	-	84	170	181	1 728,40
12GME160	B	160	7,4	2,944	160	225	-	-	240	-	2 837,90
12GME180	B	180	7,4	3,421	180	225	-	-	240	-	3 098,70
12GME200	B	200	7,4	4,396	200	250	-	-	260	-	3 262,20
12GME225	B	225	7,4	6,773	225	280	-	-	280	-	3 630,70
12GME250	B	250	7,4	10,063	250	315	-	-	320	-	6 273,00
12GME280	B	280	7,4	10,067	280	355	-	-	320	-	8 349,20
12GME315	B	315	7,4	19,600	315	400	-	-	320	-	10 052,10
12GME355**	B	355	7,4	25,233	355	450	-	-	350	-	11 274,80
12GME400**	B	400	7,4	33,500	400	500	-	-	420	-	14 835,60
12GME450**	B	450	7,4	41,000	450	560	-	-	420	-	31 252,50
12GME500**	B	500	7,4	-	500	710	-	-	480	-	37 582,80
12GME560**	C	560	7,4	70,000	560	-	612	-	520	-	79 120,40
12GME630**	B	630	7,4	-	630	800	-	-	520	-	102 857,20

ELEKTROSPÖJKY

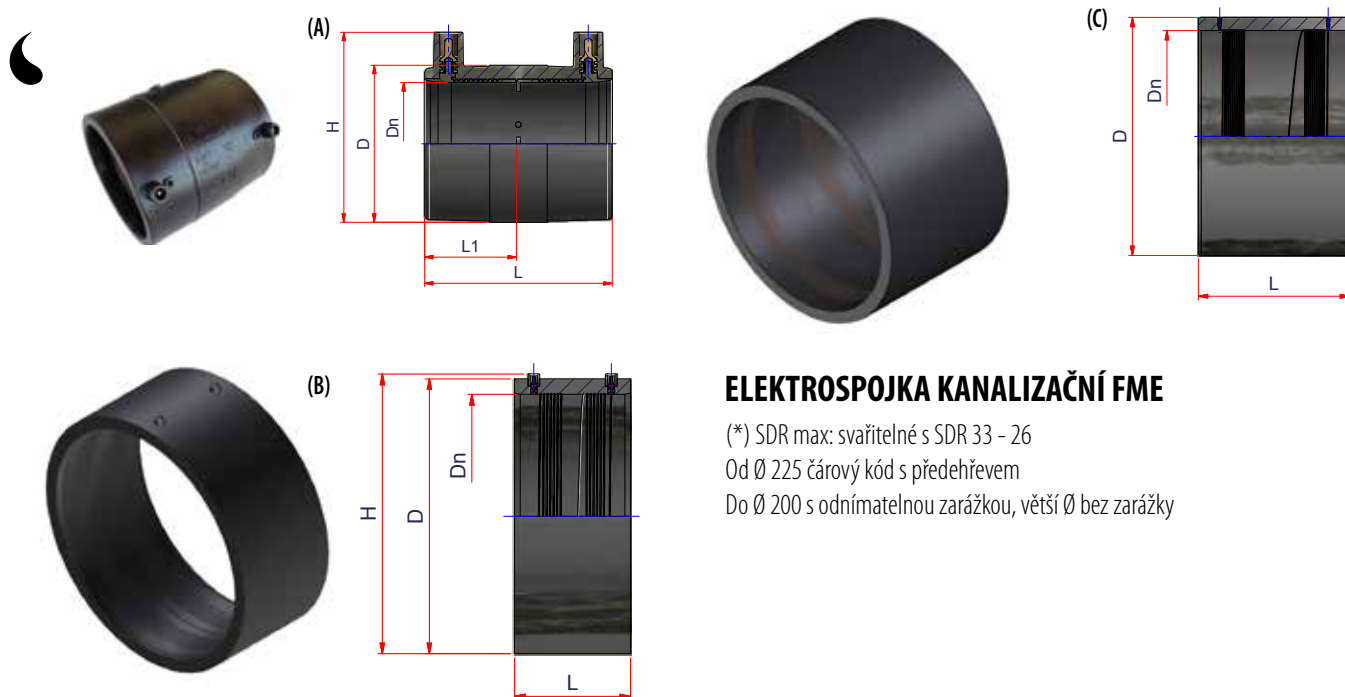

ELEKTROSPÖJKA KANALIZAČNÍ FME

(* SDR max: svařitelné s SDR 33 - 26

Od \varnothing 225 čárový kód s přehřevem

Do \varnothing 200 s odnímatelnou zářížkou, větší \varnothing bez zářížky

PE100 SDR33 U-UD BEZTLAKÉ

slevová skupina "C"

Kód	Typ	\varnothing	SDR max*	Bal.	Váha kg/ks	Dn	D	L1	L	H	Cena CZK/ks
12FME110	A	110	33	22	0,673	110	136	76,5	155	144	264,20
12FME125	A	125	33	16	1,050	125	156	82	166	168	367,30
12FME140	A	140	33	30	1,193	140	168	84	170	181	431,50
12FME160	A	160	33	24	1,508	160	191	87	175	201	486,20
12FME180	A	180	33	18	2,000	180	215	88	177	224	728,90
12FME200	A	200	33	14	2,200	200	236	92	185	243	864,10
12FME225	A	225	33	24	3,871	225	272	104	212	274	1 206,70
12FME250	A	250	33	22	4,364	250	296	106	212	300	1 270,40
12FME280	B	280	33	24	3,292	280	315	-	160	325	2 031,90
12FME315	B	315	33	18	4,389	315	355	-	160	365	2 223,30
12FME355	B	355	33	10	7,200	355	400	-	210	405	3 810,20
12FME400	B	400	33	7	8,000	400	450	-	210	455	4 444,70
12FME450	B	450	33	7	10,000	450	500	-	210	505	6 350,20
12FME500	C	500	33	8	12,100	500	560	-	210	-	6 985,30
12FME560	C	560	33	5	19,800	560	630	-	250	-	11 430,80
12FME630	C	630	33	4	24,650	630	710	-	250	-	15 875,70
12FME710	C	710	33	3	33,667	710	800	-	280	-	30 826,50
12FME800	C	800	33	1	37,800	800	900	-	280	-	36 697,50
12FME900	C	900	33	1	42,000	900	1000	-	300	-	51 376,80

ELEKTROVÍČKA

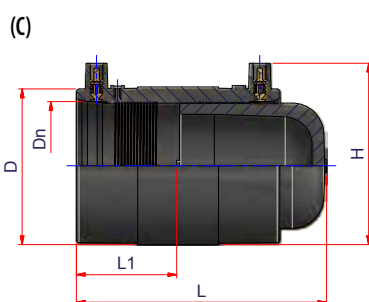
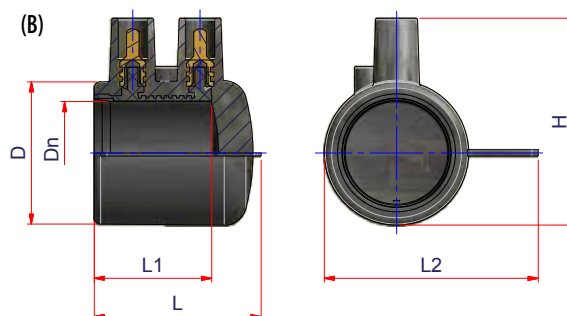
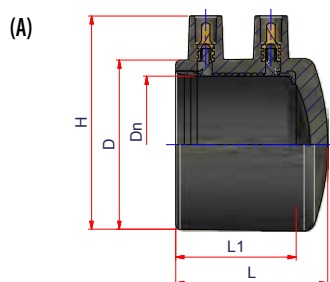

ELEKTROVÍČKO ECALE

(*) SDR max: svařitelné s SDR 17,6 - 17 - 13,6 - 11 - 9 - 7,4

Typ A a B z jednoho kusu

Typ C složený z dvou částí (ECALE+EME)

PE100 SDR11 PN16

slevová skupina "A"

Kód	Typ	ø	SDR max*	Bal.	Váha kg/ks	Dn	D	L1	L2	L	H	Cena CZK/ks
12ECALE020	C	20	17,6	30	0,067	20	33	34	-	91	53	152,30
12ECALE025	B	25	17,6	30	0,052	25	36	39,5	62,5	54	56	165,30
12ECALE032	B	32	17,6	40	0,069	32	45	36	67	52	65	189,60
12ECALE040	B	40	17,6	30	0,092	40	53	43	80	62,5	73	217,90
12ECALE050	B	50	17,6	25	0,120	50	68	46,5	89	61	86	304,10
12ECALE063	A	63	17,6	20	0,183	63	80,5	52	-	70	100	357,20
12ECALE075	C	75	17,6	20	0,530	75	98	61	-	159	114	578,90
12ECALE090	C	90	17,6	10	0,805	90	113	72	-	180	130	735,90
12ECALE110	C	110	17,6	16	1,109	110	136	76,5	-	195	144	912,80
12ECALE125	C	125	17,6	6	1,667	125	156	82	-	210	168	1 138,10
12ECALE140	C	140	17,6	8	1,950	140	168	84	-	215	181	1 561,60
12ECALE160	C	160	17,6	5	2,720	160	191	87	-	230	201	1 717,00
12ECALE180	C	180	17,6	18	3,311	180	215	88	-	220	224	2 424,00
12ECALE200	C	200	17,6	7	4,457	200	236	92	-	265	243	3 122,50
12ECALE225	C	225	17,6	1	6,400	225	272	104	-	253	274	4 766,40
12ECALE250	C	250	17,6	1	7,600	250	296	106	-	256	300	6 081,10
12ECALE280	C	280	17,6	1	14,500	280	355	-	-	227	355	9 498,60
12ECALE315	C	315	17,6	2	17,900	315	400	-	-	328	400	11 259,00



ELEKTRO T-KUSY

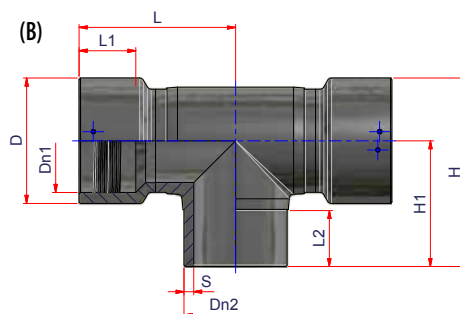
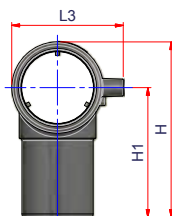
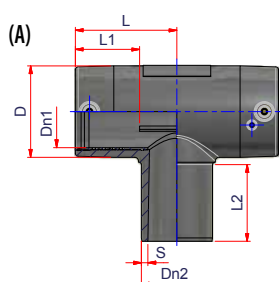

ELEKTRO T-KUS ROVNORAMENNÝ ETCE

(*) SDR max: svařitelné s SDR 17,6 - 17 - 13,6 - 11 - 9 - 7,4

Typ A jednoduché vinutí, s prodlouženým hrdlem

Typ B dvojité vinutí, s prodlouženým hrdlem

PE100 SDR11 PN16

slevová skupina "A"

Kód	Typ	ø	SDR max*	Bal.	Váha kg/ks	D1	D2	S	D	L1	L2	L3	L	H1	H	Cena CZK/ks
12ETCE020	A	20	17,6	40	0,076	20	20	3	32	37,5	46	52	45	66,5	83	230,00
12ETCE025	A	25	17,6	30	0,095	25	25	3	37	37,5	46	57	50	68,5	87	230,00
12ETCE032	A	32	17,6	25	0,120	32	32	3	44	37,5	47	64	55	75	96,5	230,00
12ETCE040	A	40	17,6	16	0,191	40	40	3,7	54	44	54	74	66,5	84	111	267,30
12ETCE050	A	50	17,6	20	0,288	50	50	4,6	65	46,5	61	85	76,5	100	133,5	336,70
12ETCE063	A	63	17,6	12	0,525	63	63	5,8	80	57	68	99	90	115	156	386,20
12ETCE075	A	75	17,6	20	0,730	75	75	6,8	95	58	72	112	98	130	178	530,20
12ETCE090	A	90	17,6	10	1,390	90	90	8,2	118	70	84	139,5	122	150	209	760,20
12ETCE110	A	110	17,6	7	1,864	110	110	10	139	83	88,5	156,5	144	177	247	994,90
12ETCE125	A	125	17,6	5	2,590	125	125	11,4	158	88	94	174	157,5	191,5	270	1298,20
12ETCE160	A	160	17,6	8	3,688	160	160	14,6	190	87	105	201,5	151	208	303	3 278,70
12ETCE180	A	180	17,6	4	6,825	180	180	16,4	210	92	105	230	165	245	350	5 005,00
12ETCE200	A	200	17,6	4	9,175	200	200	18,2	235	115	115	250	195	245	375	11 569,10
12ETCE225	B	225	17,6	2	18,500	225	225	20,5	274	124	125	-	342	275	412	17 096,40
12ETCE250	B	250	17,6	7	20,714	250	250	22,7	308	120	135	-	377	305	459	23 217,80
12ETCE315	B	315	17,6	1	-	315	315	28,6	380	155	150	-	427	350	540	30 183,40

ELEKTRO T-KUSY, ELEKTROKOLENA

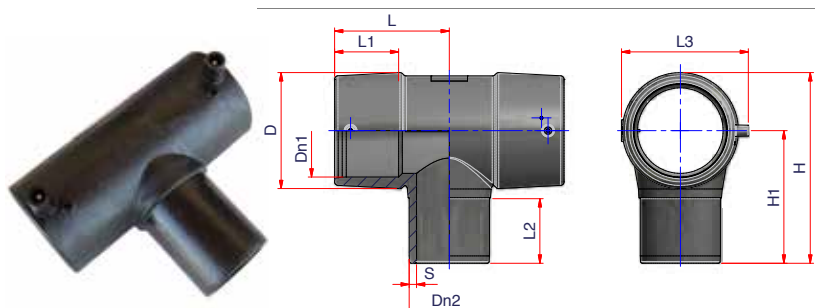

ELEKTRO T-KUS REDUKOVANÝ ETER

(*) SDR max: svařitelné s SDR 17,6 - 17 - 13,6 - 11 - 9 - 7,4

PE100 SDR11 PN16

slevová skupina "A"

Kód	ø	SDR max*	Bal.	Váha kg/ks	D1	D2	S	D	L1	L2	L3	L	H1	H	Cena CZK/ks
12ETER3220	32-20	17,6	20	0,120	32	20	3	42	37,5	45	63,5	55	70	91	380,30
12ETER1163	110-63	17,6	8	1,594	110	63	5,8	140	83	68,5	156,5	144	150	220	1 387,20
12ETER1190	110-90	17,6	8	1,725	110	90	8,2	140	83	88,5	156,5	144	170	240	1 387,20
12ETER1263	125-63	17,6	6	2,200	125	63	5,8	159	88	68,5	174	157,5	162	241,5	1 753,70
12ETER1290	125-90	17,6	6	2,333	125	90	8,2	159	88	90	174	157,5	182	261,5	1 753,70
12ETER1211	125-110	17,6	6	2,433	125	110	10	159	88	88,5	174	157,5	182	261,5	1 753,70
12ETER1663	160-63	17,6	10	3,000	160	63	5,8	195	90	78,5	206	155	185	283	3 606,40
12ETER1690	160-90	17,6	10	2,880	160	90	8,2	195	90	83,5	206	155	190	288	3 606,40
12ETER1611	160-110	17,6	10	3,020	160	110	10	195	90	88,5	206	155	195	293	3 606,40
12ETER1612	160-125	17,6	10	3,120	160	125	11,4	195	90	93,5	206	155	200	298	3 606,40

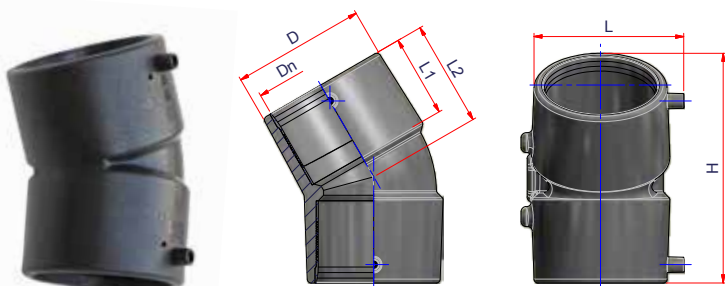

ELEKTROKOLENO 30° ECEM

(*) SDR max: svařitelné s SDR 17,6 - 17 - 13,6 - 11 - 9 - 7,4

PE100 SDR11 PN16

slevová skupina "A"

Kód	ø	SDR max*	Bal.	Váha kg/ks	Dn	D	L1	L2	L	H	Cena CZK/ks
12ECEM30090	90	17,6	20	0,688	90	119,2	70	93,6	134	209	957,60
12ECEM30110	110	17,6	12	1,050	110	134	83	107	154	233	1 027,80
12ECEM30125	125	17,6	8	1,438	125	159,4	88,6	114,5	172,5	264,5	1 397,10
12ECEM30160	160	17,6	14	2,714	160	192	87	124	208,5	279	3 419,60

ELEKTROKOLENA

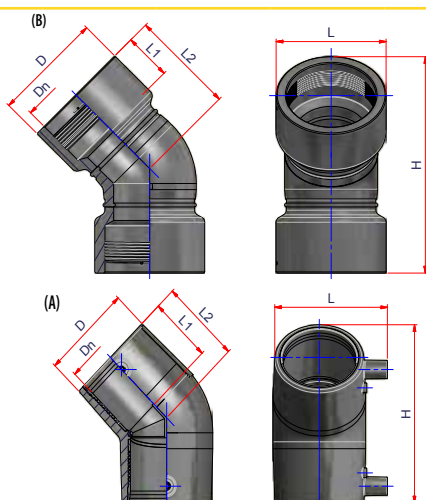

ELEKTROKOLENO 45° ECEM

(* SDR max: svařitelné s SDR 17,6 - 17 - 13,6 - 11 - 9 - 7,4

Typ A jednoduché vnutí

Typ B dvojité vnutí

PE100 SDR11 PN16

slevová skupina "A"

Kód	Typ	ø	SDR max*	Bal.	Váha kg/ks	Dn	D	L1	L2	H	Cena CZK/ks
12ECEM032	A	32	17,6	30	0,103	32	45	36	46,5	94	221,70
12ECEM040	A	40	17,6	20	0,158	40	55	41	53,5	109	267,30
12ECEM050	A	50	17,6	34	0,179	50	65	48	62,5	128	332,90
12ECEM063	A	63	17,6	20	0,250	63	80	53	68	147	381,80
12ECEM075	A	75	17,6	14	0,389	75	95	60	81	169	571,40
12ECEM090	A	90	17,6	20	0,895	90	119	70	99	208	673,40
12ECEM110	A	110	17,6	12	1,225	110	137	83	114	241	978,00
12ECEM125	A	125	17,6	8	1,856	125	170	85	122	246	1 347,60
12ECEM160	A	160	17,6	10	3,380	160	192	90	134	296	2 849,80
12ECEM180	A	180	17,6	6	4,583	180	215	106	160	340	4 786,90
12ECEM200	A	200	17,6	6	5,983	200	240	121	185	390	9 973,10
12ECE225	B	225	17,6	4	8,625	225	274	124	277	550	12 235,50
12ECE250	B	250	17,6	9	14,110	250	308	132	292	600	18 571,90
12ECE315	B	315	17,6	2	24,500	315	380	155	337	380	25 536,70

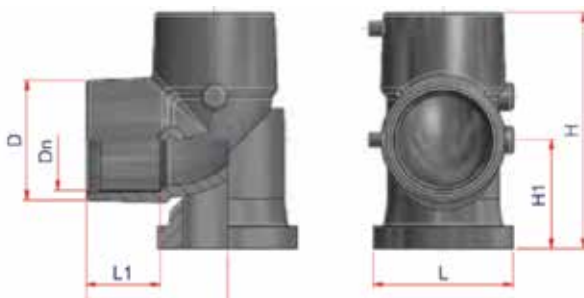

ELEKTROKOLENO 90° S PATKOU EGEMS

(* SDR max: svařitelné s SDR 17,6 - 17 - 13,6 - 11 - 9 - 7,4

PE100 SDR11 PN16

slevová skupina "A"

Kód	ø	SDR max*	Bal.	Váha kg/ks	Dn	D	L1	L2	L	H	Cena CZK/ks
12ECEM30090	90	17,6	2	1,650	90	115	70	129	158	232	2 224,20
12ECEM30110	110	17,6	2	2,150	110	134	83	159	158	266	2 657,40
12ECEM30125	125	17,6	12	3,375	125	153	88	165,5	212	292,5	3 032,60

ELEKTROKOLENA

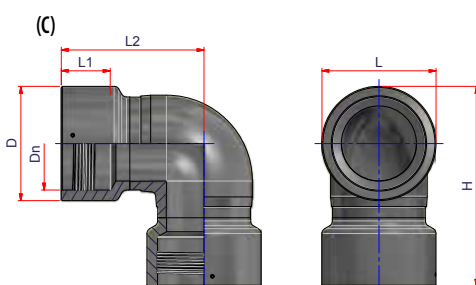
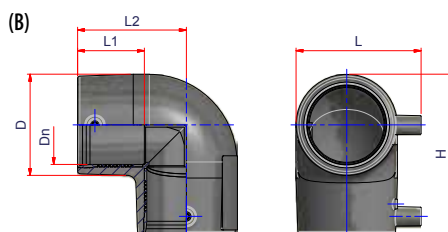
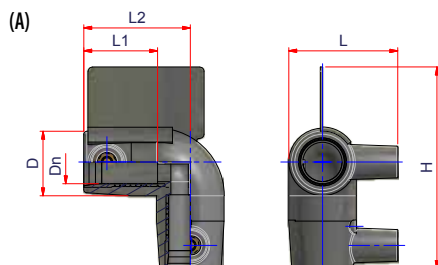

ELEKTROKOLENO 90° EGEM

(*) SDR max: svařitelné s SDR 17,6 - 17 - 13,6 - 11 - 9 - 7,4

Typ A a B jednoduché vinutí

Typ C dvojité vinutí

PE100 SDR11 PN16

slevová skupina "A"

Kód	Typ	ø	SDR max*	Bal.	Váha kg/ks	Dn	D	L1	L2	L	H	Cena CZK/ks
12EGEM020	A	20	17,6	30	0,073	20	32	34	50,5	52	95,5	221,70
12EGEM025	A	25	17,6	30	0,085	25	37	37	54	57	102	221,70
12EGEM032	B	32	17,6	20	0,115	32	45	34	57,5	64	80	221,70
12EGEM040	B	40	17,6	20	0,160	40	53	41	65	73	91,5	267,30
12EGEM050	B	50	17,6	30	0,203	50	65	48	77	84	109,5	332,90
12EGEM063	B	63	17,6	20	0,328	63	78	53	88	100	129	381,80
12EGEM075	B	75	17,6	14	0,457	75	90	58	97	110	142	571,40
12EGEM090	B	90	17,6	14	1,068	90	115	78	119	133	176	991,80
12EGEM110	B	110	17,6	10	0,143	110	139	83	144	164	214	1 135,80
12EGEM125	B	125	17,6	8	1,994	125	158	85	157,5	180	237	1 417,80
12EGEM160	B	160	17,6	12	3,250	160	192	90	173	208,5	269	2 849,80
12EGEM180	B	180	17,6	5	6,450	180	208	112	185	225	289	4 786,90
12EGEM200	B	200	17,6	5	7,870	200	230	125	205	250	320	9 973,10
12EGE225	C	225	17,6	4	10,925	225	274	124	337	274	474	14 530,70
12EGE250	C	250	17,6	8	17,125	250	308	132	385	308	539	18 574,20
12EGE315	C	315	17,6	1	27,500	315	380	155	422	380	612	25 539,00



ELEKTROREDUKCE

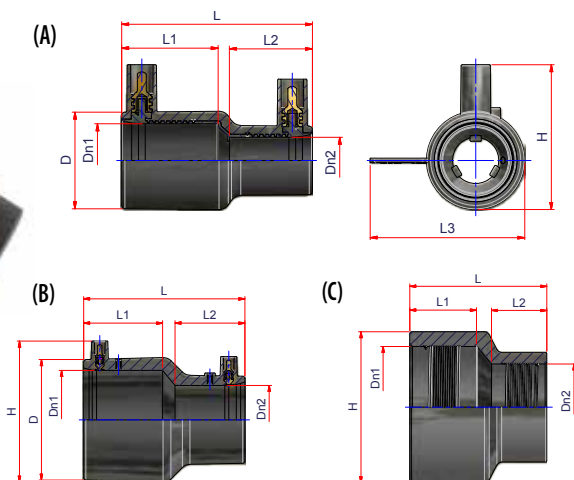

ELEKTROREDUKCE ERDE

(*) SDR max: svařitelné s SDR 17,6 - 17 - 13,6 - 11 - 9 - 7,4

Typ A a B jednoduché vinutí

Typ C dvojité vinutí

PE100 SDR11 PN16

slevová skupina "A"

Typ	ø	SDR max*	Bal.	Váha kg/ks	D1	D2	D	L1	L2	L3	L	H	Cena CZK/ks	
12ERDE2520	A	25-20	11	20	0,075	25	20	36	40	37	62	85	57	152,30
12ERDE3220	A	32-20	11	30	0,077	32	20	43	43	37	69	85	64,5	152,30
12ERDE3225	A	32-25	11	20	0,083	32	25	44	39,5	39,5	70	84,5	64,5	201,00
12ERDE4020	A	40-20	11	10	0,120	40	20	52,5	48	40	79,5	95	74	359,50
12ERDE4032	B	40-32	11	20	0,115	40	32	55	47	42	-	95	74	205,70
12ERDE5032	B	50-32	11	20	0,140	50	32	64	49,5	41,5	-	100	85	288,10
12ERDE5040	B	50-40	11	10	0,170	50	40	64	49,5	47,5	-	103	85	288,10
12ERDE6332	B	63-32	11	16	0,216	63	32	81,5	55,5	42	-	118	99	328,50
12ERDE6340	B	63-40	11	12	0,246	63	40	81,5	55	45	-	118	99	328,50
12ERDE6350	B	63-50	11	12	0,246	63	50	81,5	55,5	50	-	118	99	328,50
12ERDE7563	B	75-63	11	9	0,417	75	63	97	60	57	-	125	114	616,20
12ERDE9050	B	90-50	11	30	0,473	90	50	117	72	49	-	142	133,5	616,20
12ERDE9063	B	90-63	17,6	30	0,477	90	63	115	68	62	-	150	131	616,20
12ERDE1163	B	110-63	17,6	24	0,642	110	63	135	72,5	63	-	160	150,5	800,60
12ERDE1190	B	110-90	17,6	24	0,660	110	90	135	73	68,5	-	158	150,5	800,60
12ERDE1263	B	125-63	17,6	20	0,720	125	63	150	76	65	-	162,5	167	1 027,80
12ERDE1290	B	125-90	17,6	16	0,788	125	90	150	80	70	-	160	167	1 027,80
12ERDE1211	B	125-110	17,6	16	0,863	125	110	156	70	71,5	-	161	167	1 027,80
12ERDE1690	B	160-90	17,6	12	1,217	160	90	192	81	72	-	177	207	1 676,00
12ERDE1611	B	160-110	17,6	12	1,367	160	110	192	81	77	-	182	207	1 676,00
12ERDE1612	B	160-125	17,6	8	1,275	160	125	186	76	73,5	-	179	201	1 676,00
12ERDE2016	C	200-160	17,6	28	3,232	200	160	-	113	102	-	225	250	7 219,40
12ERDE2018	C	200-180	17,6	28	3,232	200	180	-	113	112	-	235	250	7 219,40
12ERDE2216	C	225-160	17,6	6	5,500	225	160	-	124	103	-	255	278	7 599,40
12ERDE2218	C	225-180	17,6	-	-	225	180	-	124	112	-	255	278	7 599,40
12ERDE2220	C	225-200	17,6	-	-	225	200	-	124	113	-	255	278	9 498,60
12ERDE2518	C	250-180	17,6	-	-	250	180	-	124	113	-	255	278	10 238,80
12ERDE250200	C	250-200	17,6	1	6,500	250	200	-	119	98	-	242	305	11 397,60
12ERDE2522	C	250-225	17,6	4	6,500	250	225	-	135	125	-	275	308	11 397,60
12ERDE3125	C	315-250	17,6	-	-	315	250	-	120	120	-	270	390	16 337,50
12ERDE3128	C	315-280	17,6	-	-	315	280	-	155	130	-	295	390	16 337,50

SEDLOVÉ ELEKTROTVAROVKY NAVRTÁVACÍ

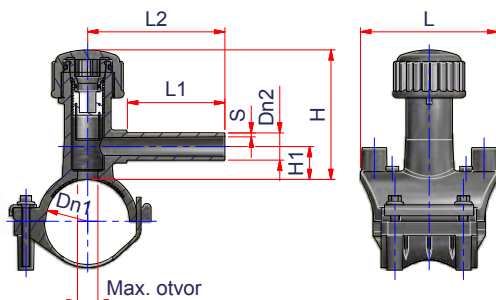

SEDLOVÁ ELEKTROTVAROVKA -NAVRTÁVACÍ T-KUS s víkem EPRES

Svařitelné s SDR 17,6 - 17 - 13,6 - 11

(*) PF (min SDR) = Maximální hloubka vrtání

⬡ Navrtávací klíč hexagon (mm)

Spodní část z PE

INSTRUKČNÍ VIDEO YouTube



PE100 SDR11 PN16

slevová skupina "A"

Kód	ø	PF (min SDR)*	Bal.	Váha kg/ks	Dn1	Dn2	S	L1	L2	L	H1	H	Max. otvor	⬡	Cena CZK/ks
12EPRES04020	40-20	11	50	0,299	40	20	3	70	100	100	24	95	17	12	591,10
12EPRES05020	50-20	11	40	0,309	50	20	3	70	100	100	24	95	17	12	645,20
12EPRES06320	63-20	11	40	0,313	63	20	3	70	100	100	24	95	17	12	700,10
12EPRES07520	75-20	11	30	0,493	75	20	3	70	100	100	24	95	17	12	833,50
12EPRES09020	90-20	11	30	0,387	90	20	3	50	100	100	20	100	17	12	833,50
12EPRES11020	110-20	11	25	0,410	110	20	3	50	100	100	20	100	17	12	917,20
12EPRES12520	125-20	11	30	0,580	125	20	3	50	100	100	20	100	17	12	1 042,80
12EPRES16020	160-20	11	20	0,690	160	20	3	70	100	100	23	110	17	12	1 453,60
12EPRES18020	180-20	11	20	0,595	180	20	3	70	100	100	23	110	17	12	1 541,10
12EPRES04025	40-25	11	40	0,303	40	25	3	70	100	100	24	95	17	12	591,10
12EPRES05025	50-25	11	40	0,318	50	25	3	70	100	100	24	95	17	12	645,20
12EPRES06325	63-25	11	40	0,318	63	25	3	70	100	100	24	95	17	12	700,10
12EPRES07525	75-25	11	30	0,343	75	25	3	70	100	100	24	95	17	12	833,50
12EPRES09025	90-25	11	30	0,527	90	25	3	50	100	100	20	100	17	12	833,50
12EPRES11025	110-25	11	20	0,440	110	25	3	50	100	100	20	100	17	12	917,20
12EPRES12525	125-25	11	25	0,808	125	25	3	70	100	100	20	100	17	12	1 042,80
12EPRES16025	160-25	11	20	0,700	160	25	3	70	100	100	23	110	17	12	1 453,60
12EPRES18025	180-25	11	20	0,680	180	25	3	70	100	100	23	110	17	12	1 541,10
12EPRES04032	40-32	11	50	0,310	40	32	3	70	100	100	24	95	17	12	591,10
12EPRES05032	50-32	11	40	0,310	50	32	3	70	100	100	24	95	17	12	645,20
12EPRES06332	63-32	11	35	0,321	63	32	3	70	100	100	24	95	17	12	700,10
12EPRES07532	75-32	11	30	0,400	75	32	3	70	100	100	24	95	17	12	833,50
12EPRES09032	90-32	11	25	0,400	90	32	3	50	100	100	20	100	17	12	833,50
12EPRES11032	110-32	11	20	0,430	110	32	3	50	100	100	20	100	17	12	917,20
12EPRES12532	125-32	11	15	0,500	125	32	3	50	100	100	20	100	17	12	1 042,80
12EPRES16032	160-32	11	20	0,680	160	32	3	70	100	100	23	110	17	12	1 453,60
12EPRES18032	180-32	11	20	0,620	180	32	3	70	100	100	23	110	17	12	1 541,10
12EPRES06340	63-40	11	25	0,556	63	40	3,7	70	100	130	32	132	23	10	1 064,30
12EPRES06350	63-50	11	20	0,820	63	50	4,6	62	100	130	32	145	31	12	1 330,00
12EPRES09050	90-50	11	10	1,850	90	50	4,6	90	136	150	62	210	40,5	12	1 381,80
12EPRES11050	110-50	11	10	1,860	110	50	4,6	90	136	150	62	210	40,5	12	1 482,60
12EPRES06363	63-63	11	20	0,855	63	63	5,8	62	100	130	32	145	31	12	1 330,00
12EPRES09063	90-63	11	10	1,900	90	63	5,8	90	136	150	62	210	40,5	14	1 381,80
12EPRES11063	110-63	11	10	1,870	110	63	5,8	90	136	150	62	210	40,5	14	1 482,60



SEDLOVÉ ELEKTROTVAROVKY NAVRTÁVACÍ

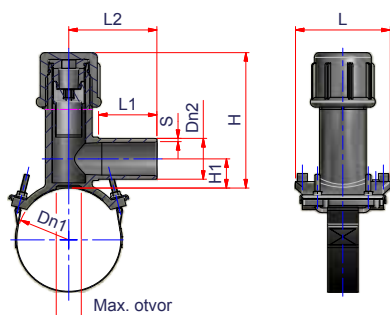

INSTRUKČNÍ VIDEO YouTube

SEDLOVÁ ELEKTROTVAROVKA -NAVRTÁVACÍ T-KUS s víkem EPRES

Svařitelné s SDR 17,6 - 17 - 13,6 - 11

(*) PF (min SDR) = Maximální hloubka vrtání

Navrtávací klíč hexagon (mm)

Spodní část třmen

PE100 SDR11 PN16

slevová skupina "A"

Kód	ø	PF (min SDR)*	Bal.	Váha kg/ks	Dn1	Dn2	S	L1	L2	L	H1	H	Max. otvor		Cena CZK/ks
12EPRES14020	140-20	11	30	0,793	140	20	3	70	105	116	30	125	24	10	1 324,10
12EPRES20020	200-20	11	30	0,780	200	20	3	70	105	116	30	125	24	10	1 813,80
12EPRES22520	225-20	11	10	1,380	225	20	3	70	105	150	42	165	24	10	1 918,20
12EPRES25020	250-20	11	10	1,400	250	20	3	70	105	150	42	165	24	10	2 689,00
12EPRES28020	280-20	11	10	1,360	280	20	3	70	105	150	42	165	24	10	2 759,90
12EPRES31520	315-20	11	10	1,360	315	20	3	70	105	150	42	165	24	10	2 835,30
12EPRES14025	140-25	11	30	0,767	140	25	3	70	105	116	30	125	24	10	1 324,10
12EPRES20025	200-25	11	25	0,736	200	25	3	70	105	116	30	125	24	10	1 813,80
12EPRES22525	225-25	11	10	1,390	225	25	3	70	105	150	42	165	24	10	1 918,20
12EPRES25025	250-25	11	10	1,380	250	25	3	70	105	150	42	165	24	10	2 689,00
12EPRES28025	280-25	11	10	1,360	280	25	3	70	105	150	42	165	24	10	2 759,90
12EPRES31525	315-25	11	10	1,360	315	25	3	70	105	150	42	165	24	10	2 835,30
12EPRES14032	140-32	11	30	0,760	140	32	3	70	105	116	30	125	24	10	1 324,10
12EPRES20032	200-32	11	30	0,767	200	32	3	70	105	116	30	125	24	10	1 813,80
12EPRES22532	225-32	11	10	1,435	225	32	3	70	105	150	42	165	24	10	1 918,20
12EPRES25032	250-32	11	10	1,410	250	32	3	70	105	150	42	165	24	10	2 689,00
12EPRES28032	280-32	11	10	1,425	280	32	3	70	105	150	42	165	24	10	2 759,90
12EPRES31532	315-32	11	10	1,445	315	32	3	70	105	150	42	165	24	10	2 835,30
12EPRES07540	75-40	11	25	0,738	75	40	3,7	70	105	116	30	125	24	10	995,60
12EPRES09040	90-40	11	25	0,738	90	40	3,7	70	105	116	30	125	24	10	905,00
12EPRES11040	110-40	11	25	0,738	110	40	3,7	70	105	116	30	125	24	10	1 215,80
12EPRES12540	125-40	11	30	0,748	125	40	3,7	70	105	116	30	125	24	10	1 407,70
12EPRES14040	140-40	11	30	0,840	140	40	3,7	70	105	116	30	125	24	10	1 394,80
12EPRES16040	160-40	11	30	0,742	160	40	3,7	70	105	116	30	125	24	10	1 600,40
12EPRES18040	180-40	11	30	0,767	180	40	3,7	70	105	116	30	125	24	10	1 612,60
12EPRES20040	200-40	11	30	0,793	200	40	3,7	70	105	116	30	125	24	10	1 884,50
12EPRES22540	225-40	11	10	1,400	225	40	3,7	70	105	150	42	165	24	10	1 989,70

SEDLOVÉ ELEKTROTVAROVKY NAVRTÁVACÍ

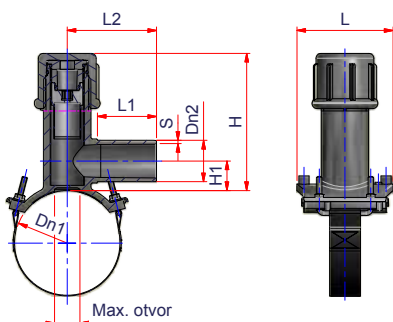

SEDLOVÁ ELEKTROTVAROVKA -NAVRTÁVACÍ T-KUS s víkem EPRES

Svařitelné s SDR 17,6 - 17 - 13,6 - 11

(*) PF (min SDR) = Maximální hloubka vrtání

⬡ Navrtávací klíč hexagon (mm)

Spodní část třmen

PE100 SDR11 PN16

slevová skupina "A"

Kód	ø	PF (min SDR)*	Bal.	Váha kg/ks	D1	D2	S	L1	L2	L	H1	H	Max. otvor	⬡	Cena CZK/ks
12EPRES07550	75-50	11	10	1,240	75	50	4,6	90	136	150	62	210	40,5	14	2 916,90
12EPRES12550	125-50	11	10	1,870	125	50	4,6	90	136	150	62	210	40,5	14	1 576,80
12EPRES14050	140-50	11	10	1,900	140	50	4,6	90	136	150	62	210	40,5	14	1 619,60
12EPRES16050	160-50	11	6	2,200	160	50	4,6	90	136	150	62	210	40,5	14	1 759,70
12EPRES18050	180-50	11	6	2,167	180	50	4,6	90	136	150	62	210	40,5	14	1 884,00
12EPRES20050	200-50	11	6	2,233	200	50	4,6	90	136	150	62	210	40,5	14	2 094,80
12EPRES22550	225-50	11	6	2,217	225	50	4,6	90	136	150	62	210	40,5	14	2 262,40
12EPRES25050	250-50	11	6	2,217	250	50	4,6	90	136	150	62	210	40,5	14	2 848,30
12EPRES28050	280-50	11	6	2,217	280	50	4,6	90	136	150	62	210	40,5	14	2 932,20
12EPRES31550	315-50	11	6	2,233	315	50	4,6	90	136	150	62	210	40,5	14	3 183,40
12EPRES07563	75-63	11	10	1,330	75	63	5,8	90	136	150	62	210	40,5	14	2 916,90
12EPRES12563	125-63	11	10	1,870	125	63	5,8	90	136	150	62	210	40,5	14	1 576,80
12EPRES14063	140-63	11	10	1,870	140	63	5,8	90	136	150	62	210	40,5	14	1 645,50
12EPRES16063	160-63	11	10	1,800	160	63	5,8	90	136	150	62	210	40,5	14	1 759,70
12EPRES18063	180-63	11	6	2,225	180	63	5,8	90	136	150	62	210	40,5	14	1 884,00
12EPRES20063	200-63	11	6	2,233	200	63	5,8	90	136	150	62	210	40,5	14	2 094,80
12EPRES22563	225-63	11	6	2,217	225	63	5,8	90	136	150	62	210	40,5	14	2 262,40
12EPRES25063	250-63	11	6	2,200	250	63	5,8	90	136	150	62	210	40,5	14	2 848,30
12EPRES28063	280-63	11	6	2,217	280	63	5,8	90	136	150	62	210	40,5	14	2 932,20
12EPRES31563	315-63	11	6	2,233	315	63	5,8	90	136	150	62	210	40,5	14	3 183,40



SEDLOVÉ ELEKTROTVAROVKY NAVRTÁVACÍ



**NAVRTÁVACÍ KLÍČ NA SEDLOVOU
ELEKTROTVAROVKU NAVRTÁVACÍ T-KUS**

slevová skupina "F"

Kód		Ø sedla	Ø odbočky	Bal.	Váha kg/ks	Cena CZK/ks
00CPRES10	Hexagon 10 mm	63-200-315	20-25-32-40-50-63	1	0,400	1 438,80
00CPRES12	Hexagon 12 mm	40-180	20-25-32	1	0,600	1 558,70
00CPRES14	Hexagon 14 mm	90-315	50-63	1	1,200	1 678,90



**UTAHOVACÍ KLÍČ NA VÍKO
SEDLOVÉ ELEKTROTVAROVKY
– NAVRTÁVACÍ T-KUS**

slevová skupina "F"

Kód	Ø	Bal.	Váha kg/ks	Cena CZK/ks
00CHIAVE025	25	1	0,045	45,40
00CHIAVE032	32	1	0,040	54,40
00CHIAVE040	40	1	0,054	63,50
00CHIAVE050	50	1	0,060	72,60

SEDLOVÉ ELEKTROTVAROVKY NAVRTÁVACÍ

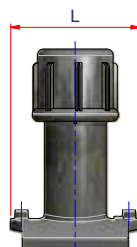
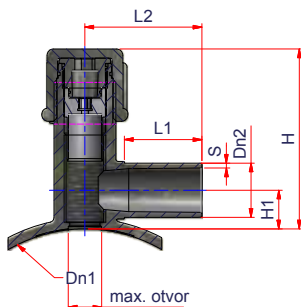

SEDLOVÁ ELEKTROTVAROVKA TOP LOAD (VYSOKOPRŮTOKOVÁ) - NAVRTÁVACÍ T-KUS s víkem EPRES

Upozornění: Instalujte pomocí pozicionéru 00POS01

PE100 SDR11 PN16

slevová skupina "A"

Kód	Ø	Sp max	Bal.	Váha kg/ks	D1	D2	S	L1	L2	L	H1	H	Max otvor	Cena CZK/ks
12EPRESTL356363	355-630/63	32	10	1,550	355÷630	63	5,8	90	136	150	59	209	44	10 471,90

TECHNICKÁ POZNÁMKA:

Dn	Max. tloušťka stěny pro navrtání (SDR min)
355	11
400	11
450	17
500	17
560	21
630	21

Sp max. (mm) - představuje maximální tloušťku potrubí v mm, na jakou je možné sedlo navrtat.



POZICIONÉR PRO TOP LOAD NAVRTÁVACÍ T-KUS

Pozicionér pro sedlové elektrotvarovky bez třmenu s hrdem Ø 63

slevová skupina "G"

Kód	Ø vrtu	Bal.	Váha kg/ks	Objem m ³ /ks	Cena CZK/ks
00POS01	63	1	3,200	0,0089	38 850,00

SEDLOVÉ ELEKTROTVAROVKY NAVRTÁVACÍ

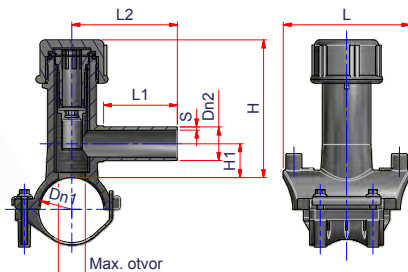

SEDLOVÁ ELEKTROTVAROVKA BEZÚNIKOVÁ

- NAVRTÁVACÍ T-KUS S VÍKEM EPRESZ

Svařitelné s SDR 17,6 - 17 - 13,6 - 11

(*) PF (min SDR) = Maximální hloubka vrtání

Nástroje pro vrtání: ráčnový klíč + navrtávací klíč 10 mm

Spodní část z PE

PE100 SDR11 PN16 MOP5

slevová skupina "A"

Kód	ø	PF (min SDR)*	Bal.	Váha kg/ks	Dn1	Dn2	S	L1	L2	L	H1	H	Max. otvor	Cena CZK/ks
12EPRESZ06332	63-32	11	30	0,517	63	32	3	70	100	116	30	130	19	2501,70
12EPRESZ09063	90-63	11	10	2,300	90	63	5,8	90	136	150	62	210	37	2520,90
12EPRESZ11063	110-63	11	10	1,940	110	63	5,8	90	136	150	62	210	37	3275,90

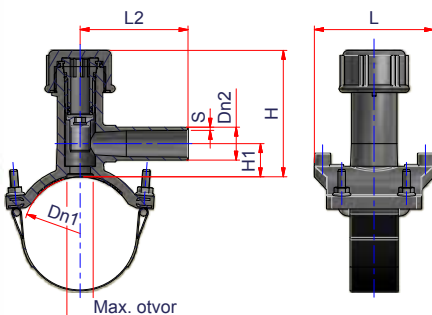

SEDLOVÁ ELEKTROTVAROVKA BEZÚNIKOVÁ – NAVRTÁVACÍ T-KUS S VÍKEM EPRESZ

Svařitelné s SDR 17,6 - 17 - 13,6 - 11

(*) PF (min SDR) = Maximální hloubka vrtání

Nástroje pro vrtání: ráčnový klíč + navrtávací klíč 10 mm

Spodní část třmen

PE100 SDR11 PN16 MOP5

slevová skupina "A"

Kód	ø	PF (min SDR)*	Bal.	Váha kg/ks	Dn1	Dn2	S	L1	L2	L	H1	H	Max. otvor	Cena CZK/ks
12EPRESZ09032	90-32	11	25	0,936	90	32	3	70	105	116	30	125	19	2501,70
12EPRESZ11032	110-32	11	30	0,843	110	32	3	70	105	116	30	125	19	2558,20
12EPRESZ12532	125-32	11	30	0,847	125	32	3	70	105	116	30	125	19	2793,60
12EPRESZ14032	140-32	11	30	0,920	140	32	3	70	105	116	30	125	19	2996,90
12EPRESZ16032	160-32	11	30	0,683	160	32	3	70	105	116	30	123	19	3163,00
12EPRESZ18032	180-32	11	30	0,957	180	32	3	70	105	116	30	123	19	3444,00
12EPRESZ20032	200-32	11	30	0,940	200	32	3	70	105	116	30	123	19	3555,90
12EPRESZ12563	125-63	11	10	2,280	125	63	5,8	90	136	150	62	210	37	2785,30
12EPRESZ14063	140-63	11	10	2,310	140	63	5,8	90	136	150	62	210	37	2996,90
12EPRESZ16063	160-63	11	6	2,650	160	63	5,8	90	136	150	62	210	37	3137,80
12EPRESZ18063	180-63	11	6	2,600	180	63	5,8	90	136	150	62	210	37	3455,60
12EPRESZ20063	200-63	11	6	2,233	200	63	5,8	90	136	150	62	210	37	3770,30
12EPRESZ22563	225-63	11	6	2,600	225	63	5,8	90	136	150	62	210	37	4510,00
12EPRESZ25063	250-63	11	6	2,233	250	63	5,8	90	136	150	62	210	37	5456,90
12EPRESZ28063	280-63	11	6	2,667	280	63	5,8	90	136	150	62	210	37	4481,80
12EPRESZ31563	315-63	11	6	2,233	315	63	5,8	90	136	150	62	210	37	6602,70

SEDLOVÉ ELEKTROTVAROVKY NAVRTÁVACÍ

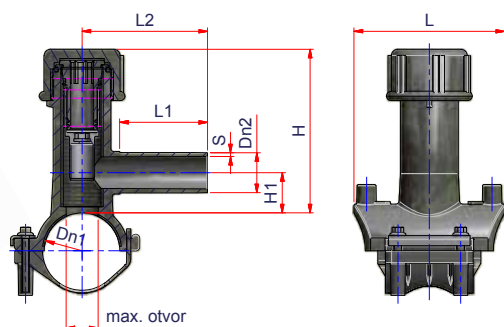

SEDLOVÁ ELEKTROTVAROVKA - NAVRTÁVACÍ T-KUS S VÍKEM (STŘEDNÍ OBJEM) EPREF

Svařitelné s SDR 17,6 - 17 - 13,6 - 11
(* PF (min SDR) = Maximální hloubka vrtání)

PE100 SDR11 PN16

Kód	ø	PF (min SDR)*	Bal.	Váha kg/ks	Dn1	Dn2	S	L1	L2	L	H1	H	Max.otvor	Cena CZK/ks
12EPREF06332	63-32	11	35	0,321	63	32	3	70	100	116	30	130	23	1015,60

SEDLOVÉ ELEKTROTVAROVKY NAVRTÁVACÍ

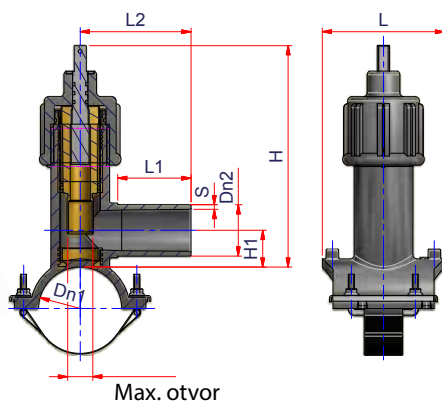

SEDLOVÁ ELEKTROTVAROVKA - NAVRTÁVACÍ T-KUS ODBOČKOVÝ S UZAVÍRACÍM VENTILEM

Svařitelné s SDR 17,6 - 17 - 13,6 - 11

(*) PF (min SDR) = Maximální hloubka vrtání

Vnitřní čtvercová koncovka 14,7 mm pro

nářadí v souladu s DIN 3223 TYP E

Typ A – spodní část s PE

Type B – spodní část třmen

PE100 SDR11 PN16 MOP5

slevová skupina "C"

Kód	Typ	ø	PF (min SDR)*	Bal.	Váha kg/ks	D1	D2	S	L1	L2	L	H1	H	Max. otvor	Cena CZK/ks
12EPREV06363	A	63-63	11	-	-	63	63	5,8	89	136	150	63	280	32,5	3 816,20
12EPREV09063	A	90-63	11	3	3,567	90	63	5,8	89	136	150	63	280	32,5	3 973,40
12EPREV11063	A	110-63	11	3	3,583	110	63	5,8	89	136	150	63	280	32,5	4 079,30
12EPREV12563	B	125-63	11	4	3,550	125	63	5,8	89	136	150	63	280	32,5	4 234,20
12EPREV14063	B	140-63	11	6	3,600	140	63	5,8	89	136	150	63	280	32,5	4 573,20
12EPREV16063	B	160-63	11	3	3,600	160	63	5,8	89	136	150	63	280	32,5	4 742,60
12EPREV18063	B	180-63	11	3	3,833	180	63	5,8	89	136	150	63	280	32,5	4 834,00
12EPREV20063	B	200-63	11	3	3,833	200	63	5,8	89	136	150	63	280	32,5	5 163,50
12EPREV22563	B	225-63	11	3	8,167	225	63	5,8	89	136	150	63	280	32,5	5 293,70
12EPREV25063	B	250-63	11	3	3,900	250	63	5,8	89	136	150	63	280	32,5	6 233,10
12EPREV28063	B	280-63	11	6	3,867	280	63	5,8	89	136	150	63	280	32,5	6 270,70
12EPREV31563	B	315-63	11	3	3,833	315	63	5,8	89	136	150	63	280	32,5	6 532,80

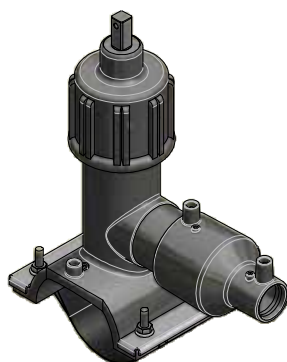

Kompatibilní s elektroredukcí Ø 63/50, 63/40 a 63/32 pro vývody Ø 50, 40, 32mm.

SEDLOVÉ ELEKTROTVAROVKY NAVRTÁVACÍ



**ZEMNÍ SOUPRAVA TELESKOPIKÁ
NA NAVRTÁVACÍ T-KUS ODBOČKOVÝ S UZAVÍRACÍM VENTILEM**

slevová skupina "E"

Kód	Bal.	Váha kg/ks	L (m)	L šroub (mm)	Cena CZK/ks
508	1	3,3	1,1-1,7	881-1489	791,50

SEDLOVÉ ELEKTROTVAROVKY HRDLOVÉ

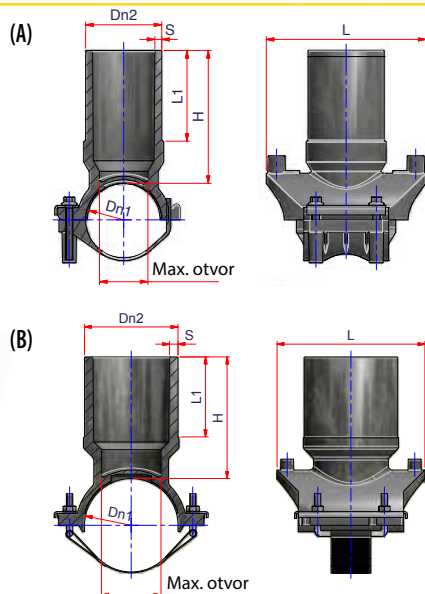

SEDLOVÁ ELEKTROTVAROVKA - HRDLOVÁ ODBOČKOVÁ ECOL

(*) SDR max: svařitelné s SDR 17,6 - 17 - 13,6 - 11 - 9 - 7,4

Typ A: spodní část z PE.

Typ B: spodní část třmen

PE100 SDR11 PN16

slevová skupina "A"

Kód	Typ	ø	SDR max*	Bal.	Váha kg/ks	D1	D2	S	L1	L	H	Max. otvor	Cena CZK/ks
12ECOL06363	A	63-63	17,6	30	0,343	63	63	5,8	75	132	110	40	836,40
12ECOL09090	B	90-90	17,6	10	1,070	90	90	8,2	100	170	131	70	2 089,70
12ECOL110110	B	110-110	17,6	10	1,240	110	110	10	95	174	143	70	2 849,80
12ECOL125125	B	125-125	17,6	8	1,500	125	125	11,4	95	204	143	84	3 685,40

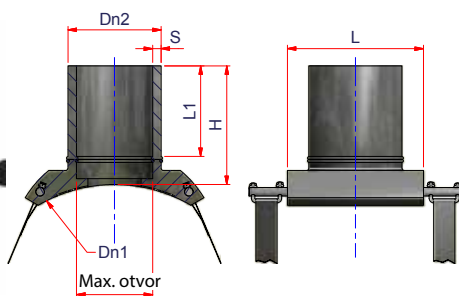

SEDLOVÁ ELEKTROTVAROVKA - HRDLOVÁ ODBOČKOVÁ (VYSOKOPRŮTOKOVÁ) ECOLTL

(*) SDR max: svařitelné s SDR 17,6

- 17 - 13,6 - 11 - 9 - 7,4

Ocelové tyče a třmeny jsou součástí dodávky - žádné další zařízení nejsou ke svařovacímu procesu potřeba.

INSTRUKČNÍ VIDEO



PE100 SDR11 PN16

slevová skupina "A"

Kód	ø	SDR max*	Bal.	Váha kg/ks	D1	D2	S	L1	L	H	Max. otvor	Cena CZK/ks
12ECOLTL160160	160-160	17,6	-	-	160	160	14,6	160	240	200	127	18 574,20
12ECOLTL180180	180-180	17,6	-	-	180	180	16,4	107	240	200	127	18 574,20
12ECOLTL200200	200-200	17,6	1	12,000	200	200	18,2	200	320	236	158	29 021,80
12ECOLTL225225	225-225	17,6	1	11,500	225	225	20,6	150	320	236	158	25 539,00

SEDLOVÉ ELEKTROTVAROVKY HRDLOVÉ

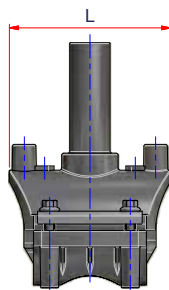
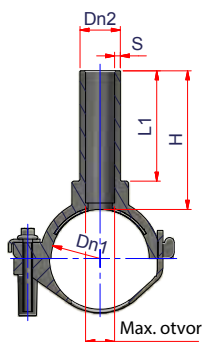

SEDLOVÁ ELEKTROTVAROVKA - HRDLOVÁ ODBOČKOVÁ ECOL

(*) SDR max: svařitelné s SDR 17,6

- 17 - 13,6 - 11 - 9 - 7,4

Spodní část z PE

PE100 SDR11 PN16

slevová skupina "A"

Kód	ø	SDR max*	Bal.	Váha kg/ks	D1	D2	S	L1	L	H	Max. otvor	Cena CZK/ks
12ECOL04020	40-20	17,6	70	0,196	40	20	3	70	100	82	13	411,30
12ECOL05020	50-20	17,6	60	0,209	50	20	3	70	100	82	13	493,70
12ECOL06320	63-20	17,6	50	0,226	63	20	3	70	100	82	13	534,10
12ECOL07520	75-20	17,6	40	0,333	75	20	3	70	100	82	13	576,10
12ECOL04025	40-25	17,6	70	0,266	40	25	3	70	100	82	16	411,30
12ECOL05025	50-25	17,6	50	0,284	50	25	3	70	100	82	16	493,70
12ECOL06325	63-25	17,6	40	0,235	63	25	3	70	100	82	16	534,10
12ECOL07525	75-25	17,6	40	0,246	75	25	3	70	100	82	16	576,10
12ECOL04032	40-32	17,6	70	0,267	40	32	3	70	100	82	22,5	411,30
12ECOL05032	50-32	17,6	40	0,295	50	32	3	70	100	82	22,5	493,70
12ECOL06332	63-32	17,6	40	0,235	63	32	3	70	100	82	22,5	534,10
12ECOL07532	75-32	17,6	40	0,250	75	32	3	70	100	82	22,5	576,10
12ECOL09032	90-32	17,6	30	0,287	90	32	3	72,5	100	97	22,5	616,20
12ECOL11032	110-32	17,6	30	0,443	110	32	3	72,5	100	97	22,5	657,40
12ECOL04040	40-40	17,6	60	0,278	40	40	3,7	70	100	82	30	411,30
12ECOL05040	50-40	17,6	50	0,294	50	40	3,7	70	100	82	30	493,70
12ECOL06340	63-40	17,6	40	0,241	63	40	3,7	70	100	82	30	534,10
12ECOL07540	75-40	17,6	40	0,340	75	40	3,7	70	100	82	30	576,10
12ECOL06350	63-50	17,6	30	0,298	63	50	4,6	75	132	110	37	684,10
12ECOL09063	90-63	17,6	20	0,410	90	63	5,8	82	140	100	44	616,20
12ECOL11063	110-63	17,6	20	0,440	110	63	5,8	82	140	100	44	657,40
12ECOL12563	125-63	17,6	15	0,467	126	63	5,8	82	140	100	44	699,30



SEDLOVÉ ELEKTROTVAROVKY HRDLOVÉ

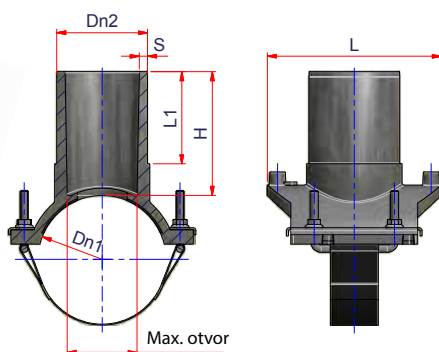

SEDLOVÁ ELEKTROTVAROVKA - HRDLOVÁ ODBOČKOVÁ ECOL

(*) SDR max: svařitelné s SDR 17,6 - 17 - 13,6 - 11 - 9 - 7,4
Spodní část třmen

PE100 SDR11 PN16

slevová skupina "A"

Kód	ø	SDR max*	Bal.	Váha kg/ks	D1	D2	S	L1	L	H	Max. otvor	Cena CZK/ks
12ECOL09020	90-20	17,6	30	0,448	90	20	3	65	140	100	13	616,20
12ECOL11020	110-20	17,6	30	0,447	110	20	3	65	140	100	13	657,40
12ECOL12520	125-20	17,6	30	0,460	125	20	3	65	140	100	13	699,30
12ECOL14020	140-20	17,6	30	0,450	140	20	3	65	140	100	13	944,60
12ECOL16020	160-20	17,6	30	0,455	160	20	3	65	140	100	13	1 072,60
12ECOL18020	180-20	17,6	30	0,470	180	20	3	65	140	100	13	1 154,90
12ECOL20020	200-20	17,6	30	0,480	200	20	3	65	140	100	13	1 426,10
12ECOL22520	225-20	17,6	30	0,487	225	20	3	65	140	100	13	1 528,90
12ECOL25020	250-20	17,6	30	0,472	250	20	3	65	140	100	13	2 284,70
12ECOL28020	280-20	17,6	30	0,487	280	20	3	65	140	100	13	2 358,50
12ECOL31520	315-20	17,6	30	0,513	315	20	3	65	140	100	13	2 358,50
12ECOL09025	90-25	17,6	30	0,447	90	25	3	65	140	100	16	616,20
12ECOL11025	110-25	17,6	30	0,447	110	25	3	65	140	100	16	657,40
12ECOL12525	125-25	17,6	30	0,453	125	25	3	65	140	100	16	699,30
12ECOL14025	140-25	17,6	30	0,460	140	25	3	65	140	100	16	944,60
12ECOL16025	160-25	17,6	30	0,457	160	25	3	65	140	100	16	1 072,60
12ECOL18025	180-25	17,6	30	0,458	180	25	3	65	140	100	16	1 154,90
12ECOL20025	200-25	17,6	30	0,483	200	25	3	65	140	100	16	1 426,10
12ECOL22525	225-25	17,6	30	0,490	225	25	3	65	140	100	16	1 528,90
12ECOL25025	250-25	17,6	30	0,497	250	25	3	65	140	100	16	2 284,70
12ECOL28025	280-25	17,6	30	0,507	280	25	3	65	140	100	16	2 358,50
12ECOL31525	315-25	17,6	30	0,483	315	25	3	65	140	100	16	2 358,50
12ECOL12532	125-32	17,6	30	0,460	125	32	3	65	140	100	22,5	699,30
12ECOL14032	140-32	17,6	30	0,460	140	32	3	65	140	100	22,5	944,60
12ECOL16032	160-32	17,6	30	0,460	160	32	3	65	140	100	22,5	1 072,60
12ECOL18032	180-32	17,6	30	0,465	180	32	3	65	140	100	22,5	1 154,90
12ECOL20032	200-32	17,6	30	0,472	200	32	3	65	140	100	22,5	1 426,10
12ECOL22532	225-32	17,6	30	0,450	225	32	3	65	140	100	22,5	1 528,90
12ECOL25032	250-32	17,6	30	0,487	250	32	3	65	140	100	22,5	2 284,70
12ECOL28032	280-32	17,6	30	0,498	280	32	3	65	140	100	22,5	2 358,50
12ECOL31532	315-32	17,6	30	0,493	315	32	3	65	140	100	22,5	2 358,50

SEDLOVÉ ELEKTROTVAROVKY HRDLOVÉ

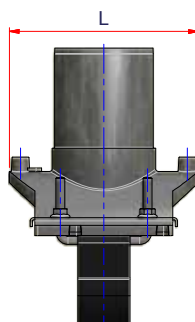
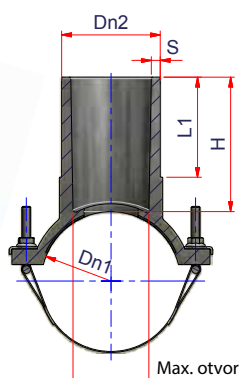

SEDLOVÁ ELEKTROTVAROVKA - HRDLOVÁ ODBOČKOVÁ ECOL

(*) SDR max: svařitelné s SDR 17,6

- 17 - 13,6 - 11 - 9 - 7,4

Spodní část třmen

PE100 SDR11 PN16

slevová skupina "A"

Kód	ø	SDR max*	Bal.	Váha kg/ks	D1	D2	S	L1	L	H	Max. otvor	Cena CZK/ks
12ECOL09040	90-40	17,6	30	0,472	90	40	3,7	65	140	100	30	616,20
12ECOL11040	110-40	17,6	30	0,468	110	40	3,7	65	140	100	30	657,40
12ECOL12540	125-40	17,6	30	0,487	125	40	3,7	65	140	100	30	699,30
12ECOL14040	140-40	17,6	30	0,473	140	40	3,7	65	140	100	30	944,60
12ECOL16040	160-40	17,6	30	0,480	160	40	3,7	65	140	100	30	1 072,60
12ECOL18040	180-40	17,6	30	0,500	180	40	3,7	65	140	100	30	1 154,90
12ECOL20040	200-40	17,6	30	0,485	200	40	3,7	65	140	100	30	1 426,10
12ECOL22540	225-40	17,6	30	0,487	225	40	3,7	65	140	100	30	1 528,90
12ECOL25040	250-40	17,6	30	0,493	250	40	3,7	65	140	100	30	2 284,70
12ECOL28040	280-40	17,6	30	0,527	280	40	3,7	65	140	100	30	2 358,50
12ECOL31540	315-40	17,6	30	0,510	315	40	3,7	65	140	100	30	2 358,50
12ECOL07550	75-50	17,6	30	0,485	75	50	4,6	65	140	100	38	576,10
12ECOL09050	90-50	17,6	30	0,487	90	50	4,6	65	140	100	38	616,20
12ECOL11050	110-50	17,6	30	0,492	110	50	4,6	65	140	100	38	657,40
12ECOL12550	125-50	17,6	30	0,487	125	50	4,6	65	140	100	38	699,30
12ECOL14050	140-50	17,6	30	0,493	140	50	4,6	65	140	100	38	944,60
12ECOL16050	160-50	17,6	30	0,498	160	50	4,6	65	140	100	38	1 072,60
12ECOL18050	180-50	17,6	30	0,495	180	50	4,6	65	140	100	38	1 154,90
12ECOL20050	200-50	17,6	30	0,500	200	50	4,6	65	140	100	38	1 426,10
12ECOL22550	225-50	17,6	30	0,533	225	50	4,6	65	140	100	38	1 528,90
12ECOL25050	250-50	17,6	30	0,512	250	50	4,6	65	140	100	38	2 284,70
12ECOL28050	280-50	17,6	30	0,520	280	50	4,6	65	140	100	38	2 358,50
12ECOL31550	315-50	17,6	30	0,527	315	50	4,6	65	140	100	38	2 358,50
12ECOL07563	75-63	17,6	25	0,532	75	63	5,8	65	140	100	44	576,10
12ECOL14063	140-63	17,6	30	0,533	140	63	5,8	65	140	100	44	944,60
12ECOL16063	160-63	17,6	30	0,535	160	63	5,8	65	140	100	44	1 072,60
12ECOL18063	180-63	17,6	30	0,540	180	63	5,8	65	140	100	44	1 154,90
12ECOL20063	200-63	17,6	30	0,537	200	63	5,8	65	140	100	44	1 426,10
12ECOL22563	225-63	17,6	30	0,533	225	63	5,8	65	140	100	44	1 528,90
12ECOL25063	250-63	17,6	30	0,545	250	63	5,8	65	140	100	44	2 284,70
12ECOL28063	280-63	17,6	30	0,550	280	63	5,8	65	140	100	44	2 358,50
12ECOL31563	315-63	17,6	30	0,573	315	63	5,8	65	140	100	44	2 358,50



SEDLOVÉ ELEKTROTVAROVKY HRDLOVÉ

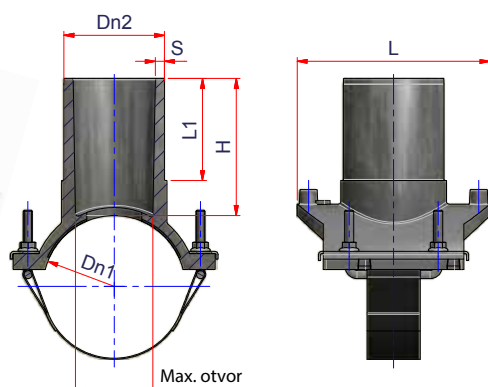

SEDLOVÁ ELEKTROTVAROVKA - HRDLOVÁ ODBOČKOVÁ (VYSOKOPRŮTOKOVÁ) ECOL

(*) SDR max: svařitelné s SDR 17,6 - 17 - 13,6 - 11 - 9 - 7,4

PE100 SDR11 PN16

slevová skupina "A"

Kód	ø	SDR max*	Bal.	Váha kg/ks	D1	D2	S	L1	L	H	Max. otvor	Cena CZK/ks
12ECOL11075	110-75	17,6	15	0,943	110	75	6,8	90	170	120	59	1 807,60
12ECOL12575	125-75	17,6	15	0,933	125	75	6,8	90	170	120	59	2 054,40
12ECOL14075	140-75	17,6	15	0,957	140	75	6,8	90	170	120	59	2 218,40
12ECOL16075	160-75	17,6	15	0,947	160	75	6,8	90	170	120	59	2 466,00
12ECOL18075	180-75	17,6	15	0,953	180	75	6,8	90	170	120	59	2 629,70
12ECOL20075	200-75	17,6	15	0,960	200	75	6,8	90	170	120	59	2 877,30
12ECOL11090	110-90	17,6	15	0,990	110	90	8,2	90	170	120	70	2 054,40
12ECOL12590	125-90	17,6	15	1,027	125	90	8,2	90	170	120	70	2 218,40
12ECOL14090	140-90	17,6	15	0,940	140	90	8,2	90	170	120	70	2 466,00
12ECOL16090	160-90	17,6	15	1,013	160	90	8,2	90	170	120	70	2 629,70
12ECOL18090	180-90	17,6	15	1,023	180	90	8,2	90	170	120	70	2 877,30
12ECOL20090	200-90	17,6	15	1,020	200	90	8,2	90	170	120	70	3 040,20
12ECOL22590	225-90	17,6	6	1,542	225	90	8,2	98	200	130	70	3 287,80
12ECOL25090	250-90	17,6	6	1,525	250	90	8,2	98	200	130	70	3 451,50
12ECOL28090	280-90	17,6	6	1,500	280	90	8,2	98	200	130	70	3 697,50
12ECOL31590	315-90	17,6	6	1,533	315	90	8,2	98	200	130	70	3 862,30
12ECOL125110	125-110	17,6	10	1,380	125	110	10	90	200	140	87	2 794,10
12ECOL160110	160-110	17,6	7	1,464	160	110	10	98	200	130	87	2 877,30
12ECOL180110	180-110	17,6	6	1,475	180	110	10	98	200	130	87	3 040,20
12ECOL200110	200-110	17,6	8	1,438	200	110	10	98	200	130	87	3 287,80
12ECOL225110	225-110	17,6	5	1,700	225	110	10	98	200	130	87	3 451,50
12ECOL250110	250-110	17,6	5	1,730	250	110	10	98	200	130	87	3 697,50
12ECOL280110	280-110	17,6	5	1,720	280	110	10	98	200	130	87	3 862,30
12ECOL315110	315-110	17,6	6	1,692	315	110	10	98	200	130	87	4 109,10
12ECOL160125	160-125	17,6	6	1,667	160	125	11,4	98	200	130	100	3 040,20
12ECOL180125	180-125	17,6	6	1,633	180	125	11,4	98	200	130	100	3 287,80
12ECOL200125	200-125	17,6	5	1,690	200	125	11,4	98	200	130	100	3 451,50
12ECOL225125	225-125	17,6	5	1,800	225	125	11,4	98	200	130	100	3 697,50
12ECOL250125	250-125	17,6	5	1,850	250	125	11,4	98	200	130	100	3 862,30
12ECOL280125	280-125	17,6	5	1,880	280	125	11,4	98	200	130	100	4 109,10
12ECOL315125	315-125	17,6	6	1,833	315	125	11,4	98	200	130	100	4 273,50

SEDLOVÉ ELEKTROTVAROVKY HRDLOVÉ

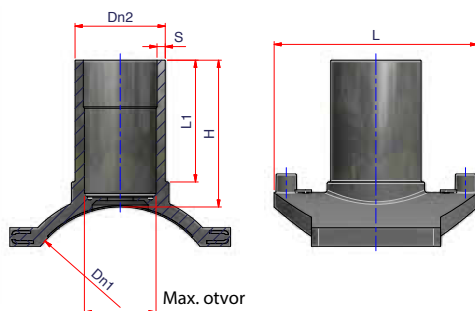

SEDLOVÁ ELEKTROTVAROVKA - HRDLOVÁ ODBOČKOVÁ TOP LOAD (VYSOKOPRŮTOKOVÁ) ECOLTL

(*) SDR max: svařitelné s SDR 17,6

- 17 - 13,6 - 11 - 9 - 7,4

Upozornění: Instalujte pomocí pozicionéru 00POS01

PE100 SDR11 PN16

slevová skupina "A"

Kód	Ø	SDR max*	Bal.	Váha kg/ks	D1	D2	S	L1	L	H	Max. otvor	Cena CZK/ks
12ECOLTL356363	355÷630-63	17,6	30	0,333	355÷630	63	5,8	85	140	102	47	4 519,60

slevová skupina "G"



POZICIONÉR PRO TOP LOAD SEDLOVOU ELEKTROTVAROVKU

Pozicionér pro sedlové elektrotvarovky bez třmenu s hrdem Ø 63

Kód	Ø vrtu	Bal.	Váha kg/ks	Objem m ³ /ks	Cena CZK/ks
00POS01	63	1	3,200	0,0089	38850,00



SEDLOVÉ ELEKTROTVAROVKY HRDLOVÉ

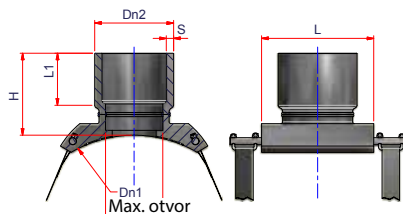

SEDLOVÁ ELEKTROTVAROVKA - HRDLOVÁ ODBOČKOVÁ (VYSOKOPRŮTOKOVÁ) ECOTL

(*) SDR max: svařitelné s SDR 17,6 - 17 - 13,6 - 11 - 9 - 7,4
Ocelové tyče a třmeny jsou součástí dodávky - žádné další zařízení nejsou ke svařovacímu procesu potřeba.

INSTRUKČNÍ VIDEO 



PE100 SDR11 PN16 MOP5

slevová skupina "A"

Kód	ø	SDR max*	Bal.	Váha kg/ks	D1	D2	S	L1	L	H	Max. otvor	Cena CZK/ks
12ECOLTL180160	180-160	17,6	2	8,000	225	160	14,6	160	240	200	127	20 896,20
12ECOLTL200160	200-160	17,6	2	8,000	200	160	14,6	160	240	200	127	20 896,20
12ECOLTL225160	225-160	17,6	2	8,000	225	160	14,6	160	240	200	127	20 896,20
12ECOLTL250160	250-160	17,6	2	8,000	250	160	14,6	160	240	200	127	20 896,20
12ECOLTL280160	280-160	17,6	2	8,000	280	160	14,6	160	240	200	127	20 896,20
12ECOLTL315160	315-160	17,6	2	8,000	315	160	14,6	160	240	200	127	20 896,20
12ECOLTL355160	355-160	17,6	2	8,000	355	160	14,6	160	240	200	127	23 217,80
12ECOLTL400160	400-160	17,6	2	8,000	400	160	14,6	160	240	200	127	29 022,50
12ECOLTL450160	450-160	17,6	2	8,000	450	160	14,6	160	240	200	127	30 182,60
12ECOLTL500160	500-160	17,6	2	8,000	500	160	14,6	160	240	200	127	32 505,30
12ECOLTL560160	560-160	17,6	2	8,000	560	160	14,6	160	240	200	127	34 827,30
12ECOLTL630160	630-160	17,6	2	8,000	630	160	14,6	160	240	200	127	37 149,20
12ECOLTL710160	710-160	17,6	2	8,000	710	160	14,6	160	240	200	127	39 470,10
12ECOLTL800160	800-160	17,6	2	8,000	800	160	14,6	160	240	200	127	41 792,00
12ECOLTL900160	900-160	17,6	2	8,000	900	160	14,6	160	240	200	127	48 758,30
12ECOLTL1000160	1000-160	17,6	2	8,000	1000	160	14,6	160	240	200	127	85 906,70
12ECOLTL200180	200-180	17,6	2	8,000	200	180	16,4	107	240	200	127	20 896,20
12ECOLTL225180	225-180	17,6	2	8,000	225	180	16,4	107	240	200	127	20 896,20
12ECOLTL250180	250-180	17,6	2	8,000	250	180	16,4	107	240	200	127	20 896,20
12ECOLTL280180	280-180	17,6	2	8,000	280	180	16,4	107	240	200	127	20 896,20
12ECOLTL315180	315-180	17,6	2	8,000	315	180	16,4	107	240	200	127	20 896,20
12ECOLTL355180	355-180	17,6	2	8,000	355	180	16,4	107	240	200	127	23 217,80
12ECOLTL400180	400-180	17,6	2	8,000	400	180	16,4	107	240	200	127	29 022,50
12ECOLTL450180	450-180	17,6	2	8,000	450	180	16,4	107	240	200	127	30 182,60
12ECOLTL500180	500-180	17,6	2	8,000	500	180	16,4	107	240	200	127	32 505,30
12ECOLTL560180	560-180	17,6	2	8,000	560	180	16,4	107	240	200	127	34 827,30
12ECOLTL630180	630-180	17,6	2	8,000	630	180	16,4	107	240	200	127	37 149,20
12ECOLTL710180	710-180	17,6	2	8,000	710	180	16,4	107	240	200	127	39 470,10
12ECOLTL800180	800-180	17,6	2	8,000	800	180	16,4	107	240	200	127	41 792,00
12ECOLTL900180	900-180	17,6	2	8,000	900	180	16,4	107	240	200	127	48 758,30
12ECOLTL1000180	1000-180	17,6	2	8,000	1000	180	16,4	107	240	200	127	85 906,70

SEDLOVÉ ELEKTROTVAROVKY HRDLOVÉ

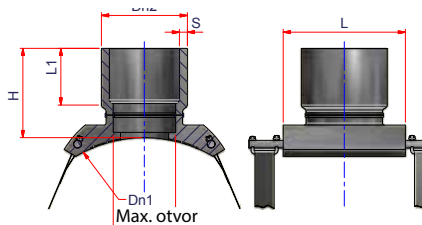

SEDLOVÁ ELEKTROTVAROVKA - HRDLOVÁ ODBOČKOVÁ (VYSOKOPRŮTOKOVÁ) ECOTL

(*) SDR max: svařitelné s SDR 17,6

- 17 - 13,6 - 11 - 9 - 7,4

Ocelové tyče a třmeny jsou součástí dodávky - žádné další zařízení nejsou ke svařovacímu procesu potřeba.

INSTRUKTÁŽNÍ VIDEO



PE100 SDR11 PN16

slevová skupina "A"

Kód	ø	SDR max*	Bal.	Váha kg/ks	D1	D2	S	L1	L	H	Max. otvor	Cena CZK/ks
12ECOLTL225200	225-200	17,6	1	14,000	225	200	18,2	200	320	236	158	23 217,10
12ECOLTL280200	280-200	17,6	1	14,000	280	200	18,2	200	320	236	158	27 862,50
12ECOLTL315200	315-200	17,6	1	14,000	315	200	18,2	200	320	236	158	30 182,60
12ECOLTL355200	355-200	17,6	1	14,000	355	200	18,2	200	320	236	158	32 505,30
12ECOLTL400200	400-200	17,6	1	14,000	400	200	18,2	200	320	236	158	37 149,20
12ECOLTL450200	450-200	17,6	1	14,000	450	200	18,2	200	320	236	158	41 792,00
12ECOLTL500200	500-200	17,6	1	14,000	500	200	18,2	200	320	236	158	44 114,70
12ECOLTL560200	560-200	17,6	1	14,000	560	200	18,2	200	320	236	158	46 435,60
12ECOLTL630200	630-200	17,6	1	14,000	630	200	18,2	200	320	236	158	48 758,30
12ECOLTL710200	710-200	17,6	1	14,000	710	200	18,2	200	320	236	158	58 045,10
12ECOLTL800200	800-200	17,6	1	14,000	800	200	18,2	200	320	236	158	62 688,10
12ECOLTL900200	900-200	17,6	1	14,000	900	200	18,2	200	320	236	158	81 262,80
12ECOLTL1000200	1000-200	17,6	1	14,000	1000	200	18,2	200	320	236	158	134 084,60
12ECOLTL250225	250-225	17,6	1	14,000	250	225	20,6	150	320	236	158	30 182,60
12ECOLTL280225	280-225	17,6	1	14,000	280	225	20,6	150	320	236	158	32 505,30
12ECOLTL315225	315-225	17,6	1	14,000	315	225	20,6	150	320	236	158	34 826,50
12ECOLTL355225	355-225	17,6	1	14,000	355	225	20,6	150	320	236	158	38 310,00
12ECOLTL400225	400-225	17,6	1	14,000	400	225	20,6	150	320	236	158	42 953,60
12ECOLTL450225	450-225	17,6	1	14,000	450	225	20,6	150	320	236	158	45 589,50
12ECOLTL500225	500-225	17,6	1	14,000	500	225	20,6	150	320	236	158	47 879,30
12ECOLTL560225	560-225	17,6	1	14,000	560	225	20,6	150	320	236	158	50 121,20
12ECOLTL630225	630-225	17,6	1	14,000	630	225	20,6	150	320	236	158	52 439,30
12ECOLTL710225	710-225	17,6	1	14,000	710	225	20,6	150	320	236	158	63 823,90
12ECOLTL800225	800-225	17,6	1	14,000	800	225	20,6	150	320	236	158	68 383,00
12ECOLTL900225	900-225	17,6	1	14,000	900	225	20,6	150	320	236	158	91 176,60
12ECOLTL1000225	1000-225	17,6	1	14,000	1000	225	20,6	150	320	236	158	153 343,60
12ECOLTL630250	630-250	17,6	1	14,000	630	250	22,7	240	500	300	250	257 977,30
12ECOLTL630315	630-315	17,6	1	14,000	630	315	28,6	260	500	340	250	335 370,30



SEDLOVÉ ELEKTROTVAROVKY BALONOVACÍ

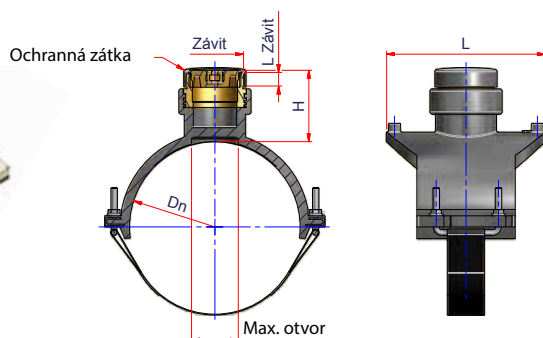

SEDLOVÁ ELEKTROTVAROVKA - BALONOVACÍ EPALG

(*) SDR max: svařitelné s SDR 17,6

- 17 - 13,6 - 11 - 9 - 7,4

Vývod s vnitřním závitem z mosazi.

Zvláštní otvor optimalizovaný pro protiskluzové balónky (specifické pro PE).

Vyměnitelná ochranná zátka.

PE100 SDR11 PN16

slevová skupina "A"

Kód	ø	SDR max*	Bal.	Váha kg/ks	Dn	Závit	L Závit	L	H	Max. otvor	Cena CZK/ks
12EPALG090	90	17,6	5	1,900	90	2"1/2	17,5	170	70	62	2519,10
12EPALG110	110	17,6	10	1,920	110	2"1/2	17,5	170	85	62	2603,80
12EPALG125	125	17,6	10	1,865	125	2"1/2	17,5	170	85	62	2730,20
12EPALG140	140	17,6	10	1,915	140	2"1/2	17,5	170	85	62	3018,20
12EPALG160	160	17,6	10	1,930	160	2"1/2	17,5	170	85	62	3145,30
12EPALG180	180	17,6	10	1,920	180	2"1/2	17,5	170	85	62	3232,90
12EPALG200	200	17,6	10	2,020	200	2"1/2	17,5	170	85	62	3513,40
12EPALG225	225	17,6	5	2,450	225	2"1/2	17,5	200	70	62	3615,40
12EPALG250	250	17,6	5	2,600	250	2"1/2	17,5	200	70	62	4394,00
12EPALG280	280	17,6	5	2,480	280	2"1/2	17,5	200	70	62	4444,20
12EPALG315	315	17,6	5	2,460	315	2"1/2	17,5	200	70	62	4655,80

SEDLOVÉ ELEKTROTVAROVKY BALONOVACÍ



SEDLOVÁ ELEKTROTVAROVKA - BALONOVACÍ TOP LOAD (VYSOKOPRŮTOKOVÁ) EPALTL

(*) SDR max: svařitelné s SDR 17,6
- 17 - 13,6 - 11 - 9 - 7,4

Vývod s vnitřním závitem z mosazi.

Zvláštní otvor optimalizovaný pro protiskluzové balónky (specifické pro PE).

Instalace pomocí kovových tyčí a třmenů (součástí dodávky).

Vyměnitelná ochranná zátka.

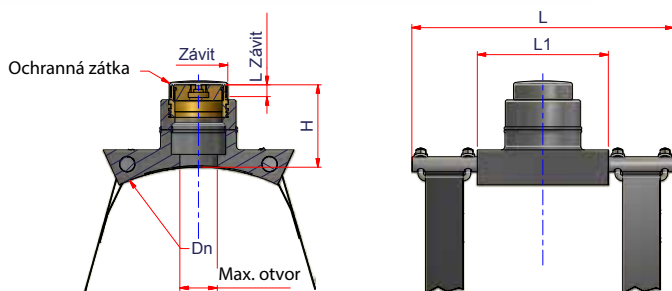

PE100 SDR11 PN16

slevová skupina "A"

Kód	ø	SDR max*	Bal.	Váha kg/ks	Dn	Závit	L Závit	L1	L	H	Max. otvor	Cena CZK/ks
12EPALTL355	355	17,6	1	-	355	2" 1/2	17,5	175	350	110	60	23461,80
12EPALTL400	400	17,6	1	-	400	2" 1/2	17,5	175	350	110	60	28349,20
12EPALTL450	450	17,6	1	-	450	2" 1/2	17,5	175	350	110	60	29327,10
12EPALTL500	500	17,6	1	-	500	2" 1/2	17,5	175	350	110	60	31281,80
12EPALTL560	560	17,6	1	-	560	2" 1/2	17,5	175	350	110	60	33237,30
12EPALTL630	630	17,6	1	-	630	2" 1/2	17,5	175	350	110	60	35192,70



SEDLOVÉ ELEKTROTVAROVKY OPRAVÁRENSKÉ



Maximální plocha poškození A

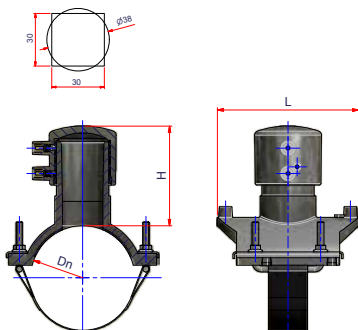

SEDLOVÁ ELEKTROTVAROVKA - OPRAVÁRENSKÁ (STŘEDNÍ PLOCHY) ERIP

(* SDR max: svařitelné s SDR 17,6 - 17 - 13,6 - 11 - 9 - 7,4

* Skládá se ze sedlové elektrotvarovky hrdlové 12ECOL a elektrovíčka 12ECALE063

• Skládá se ze sedlové elektrotvarovky hrdlové 12ECOL a víčka pro svařování na tupo
Vhodné k opravě drobných poškození potrubí s únikem nebo bez úniku média.

Maximální plocha poškození B

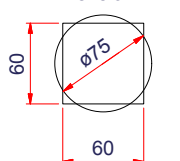

Maximální plocha poškození C

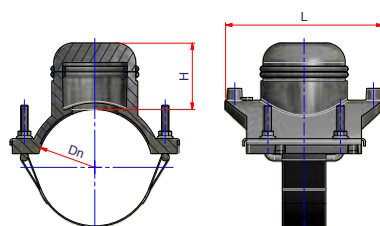
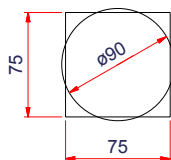

PE100 SDR11 PN16

slevová skupina "A"

Kód	Ø	SDR max*	Bal.	Váha kg/ks	Dn	L	H	Maximální plocha poškození	Cena CZK/ks
12ERIP075 *	75	17,6	10	0,680	75	140	120	A	890,50
12ERIP090 *	90	17,6	10	0,700	90	140	120	A	1950,80
12ERIP110 •	110	17,6	10	0,720	110	170	80	B	2053,70
12ERIP125 •	125	17,6	10	0,720	125	170	80	B	2463,70
12ERIP140 •	140	17,6	10	0,720	140	170	80	B	2668,50
12ERIP160 •	160	17,6	10	0,740	160	170	80	B	3079,80
12ERIP180 •	180	17,6	10	0,740	180	170	80	B	4106,00
12ERIP200 •	200	17,6	10	0,720	200	200	90	C	14370,70
12ERIP225 •	225	17,6	10	0,740	225	200	90	C	14370,70
12ERIP250 •	250	17,6	10	0,740	250	200	90	C	14370,70
12ERIP280 •	280	17,6	10	0,780	280	200	90	C	14370,70

SEDLOVÉ ELEKTROTVAROVKY OPRAVÁRENSKÉ



Maximální plocha poškození D

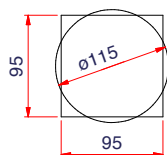

SEDLOVÁ ELEKTROTVAROVKA - OPRAVÁRENSKÁ (VELKÉ PLOCHY) ERIP

(*) SDR max: svařitelné s SDR 17,6 - 17 - 13,6 - 11 - 9 - 7,4
Vhodné k opravě poškozeného potrubí.

Instalace pomocí kovových tyčí a řemenů (součástí dodávky).
Dostupné na poptávku.

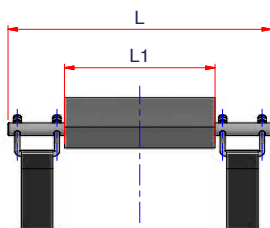
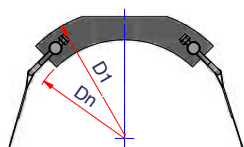

PE100 SDR11 PN16

slevová skupina "A"

Kód	ø	SDR max*	Bal.	Váha kg/ks	Dn	D1	L1	L	Maximální plocha poškození	Cena CZK/ks
12ERIP315	315	17,6	1	-	315	400	240	420	D	16636,90
12ERIP355	355	17,6	1	-	355	450	240	420	D	17293,00
12ERIP400	400	17,6	1	-	400	500	240	420	D	17916,90
12ERIP450	450	17,6	1	-	450	560	240	420	D	20529,70
12ERIP500	500	17,6	1	-	500	612	240	420	D	21556,60
12ERIP560	560	17,6	1	-	560	630	240	420	D	22582,50
12ERIP630	630	17,6	1	-	630	710	240	420	D	26202,60
12ERIP710	710	17,6	1	-	710	800	240	420	D	28741,50
12ERIP800	800	17,6	1	-	800	900	240	420	D	30794,40
12ERIP900	900	17,6	1	-	900	1000	240	420	D	41059,30
12ERIP1000	1000	17,6	1	-	1000	1000	240	420	D	71853,60





2



EloFIT

TVAROVKY PRO SVAŘOVÁNÍ NA TUPO HDPE PE100 PRO TLAKOVÉ
ROZVODY PLYNU, VODY A KANALIZACE

TVAROVKY VSTŘIKOVANÉ



(A)

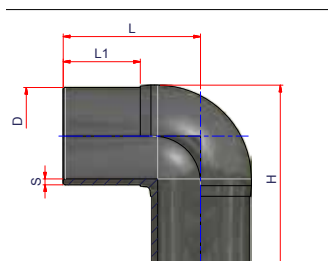

KOLENO 90° S DLOUHÝMI KONCI DG

* Krátká tvarovka s navařenými konci z PE potrubí

(B)

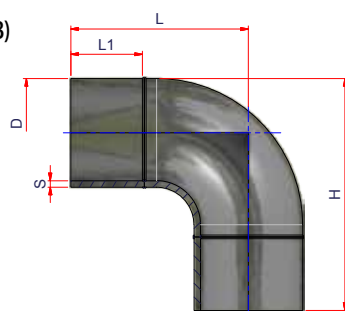

PE100 SDR17 PN10

slevová skupina "B"

Kód	Typ	ø	Bal.	Váha kg/ks	D, OD	S	L1	L	H	Cena CZK/ks
12DG063	A	63	10	0,320	63	3,8	70	120	154	205,40
12DG075	A	75	6	0,517	75	4,5	70	120	167,5	248,20
12DG090	A	90	24	0,583	90	5,4	89	146	197	279,30
12DG110	A	110	12	0,875	110	6,6	87	155	212,5	472,20
12DG125	A	125	24	1,260	125	7,4	95	185	250,5	621,10
12DG140	A	140	20	1,750	140	8,3	97	195	268	837,90
12DG160	A	160	55	2,263	160	9,5	101	203	293,5	993,30
12DG180	A	180	18	3,300	180	10,7	109	225	325	1 179,80
12DG200	A	200	16	4,513	200	11,9	116	250	355	1 552,80
12DG225	A	225	10	6,100	225	13,4	125	275	392	1 863,00
12DG250	A	250	13	8,154	250	14,8	135	302	432	4 515,70
12DG280	A	280	6	10,233	280	16,6	140	340	485	6 813,00
12DG315	A	315	9	16,511	315	18,7	165	360	518	8 530,20
12DG355*	B	355	2	24,800	355	21,1	210	550	727,5	16 536,70
12DG400*	B	400	2	31,300	400	23,7	300	640	840	24 218,50
12DG450*	B	450	1	-	450	26,7	300	745	970	33 390,30
12DG500*	B	500	1	-	500	29,7	300	745	995	45 896,10

* jiné rozměry na poptávku

TVAROVKY VSTŘIKOVANÉ

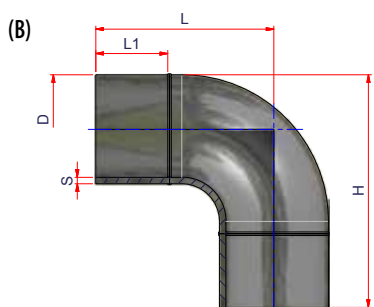
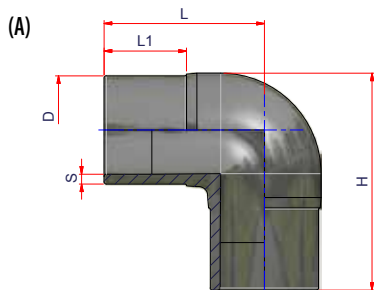

KOLENO 90° S DLOUHÝMI KONCI EG

* Krátká tvarovka s navařenými konci z PE potrubí

PE100 SDR11 PN16

slevová skupina "B"

Kód	Typ	ø	Bal.	Váha kg/ks	D, OD	S	L1	L	H	Cena CZK/ks
12EG025	A	25	50	0,036	25	3	45	70	92,5	95,40
12EG032	A	32	50	0,056	32	3	50	75	101	104,40
12EG040	A	40	30	0,098	40	3,7	55	85	115	124,40
12EG050	A	50	20	0,155	50	4,6	55	90	125	167,90
12EG063	A	63	50	0,289	63	5,8	70	120	154	248,20
12EG075	A	75	6	0,492	75	6,8	70	120	167,5	279,30
12EG090	A	90	24	0,725	90	8,2	89	146	197	304,40
12EG110	A	110	12	1,100	110	10	87	155	212,5	524,50
12EG125	A	125	24	1,704	125	11,4	95	184	250,5	753,20
12EG140	A	140	20	2,320	140	12,7	97	195	268	1 055,00
12EG160	A	160	55	3,164	160	14,6	101	203	293,5	1 179,80
12EG180	A	180	18	4,422	180	16,4	109	225	325	1 366,30
12EG200	A	200	16	5,938	200	18,2	116	250	355	2 098,70
12EG225	A	225	18	7,722	225	20,5	125	275	392	2 273,60
12EG250	A	250	14	11,214	250	22,7	135	302	432	4 973,60
12EG280	A	280	6	13,817	280	25,4	140	340	485	8 496,50
12EG315	A	315	4	22,400	315	28,6	165	360	518	10 700,10
12EG355*	B	355	2	36,300	355	32,2	210	550	727,5	22 998,00
12EG400*	B	400	2	44,875	400	36,3	300	645	845	30 698,80
12EG450*	B	450	1	-	450	40,9	300	745	970	42 219,60
12EG500*	B	500	1	-	500	45,4	300	745	995	60 302,50

* jiné rozměry na poptávku

TVAROVKY VSTŘIKOVANÉ

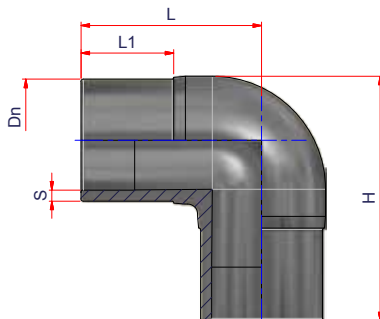

KOLENO 90° S DLOUHÝMI KONCI GG

PE100 SDR7,4 PN25

slevová skupina "B"

Kód	ø	Bal.	Váha kg/ks	Dn	S	L1	L	H	Cena CZK/ks
12GG063	63	25	0,320	63	8,6	70	110	154	455,20
12GG075	75	-	0,517	75	10,3	70	120	167,5	695,60
12GG090	90	24	1,004	90	12,3	89	146	197	1008,00
12GG110	110	4	1,725	110	15,1	87	155	212,5	1568,30
12GG125	125	-	1,260	125	17,1	95	185	250,5	3478,40
12GG140	140	-	3,650	140	19,2	97	195	268	4413,50
12GG160	160	5	4,400	160	21,9	101	203	293,5	5552,90
12GG180	180	8	5,856	180	24,6	109	225	325	7248,20
12GG200	200	6	8,000	200	27,4	116	250	355	8563,30
12GG225	225	10	10,550	225	30,8	125	275	392	10604,80
12GG250	250	6	15,333	250	34,2	135	302	432	16268,10
12GG280	280	-	21,579	280	38,3	140	340	485	25127,30
12GG315	315	4	27,725	315	43,1	150	350	508	27482,80

TVAROVKY VSTŘIKOVANÉ

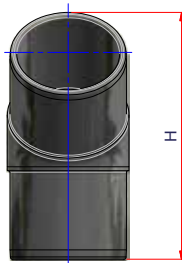
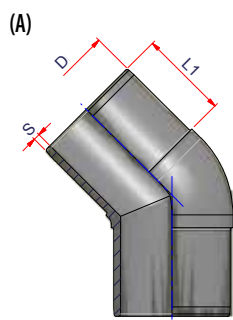

KOLENO 45° S DLOUHÝMI KONCI DC

* Krátká tvarovka s navařenými konci z PE potrubí

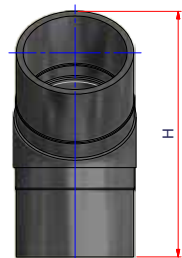
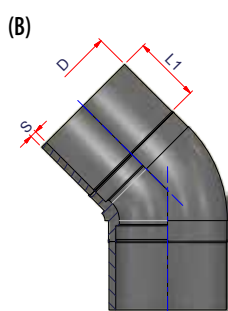

PE100 SDR17 PN10

slevová skupina "B"

Kód	Typ	ø	Bal.	Váha kg/ks	D, OD	S	L1	H	Cena CZK/ks
12DC063	A	63	10	0,260	63	3,8	69	210	187,30
12DC075	A	75	20	0,365	75	4,5	73	225	258,50
12DC090	A	90	25	0,466	90	5,4	90	235	350,50
12DC110	A	110	12	0,696	110	6,6	87	242	403,60
12DC125	A	125	10	0,940	125	7,4	95	264,5	590,10
12DC140	A	140	8	1,188	140	8,3	97	287	713,60
12DC160	A	160	6	1,708	160	9,5	102	311	869,00
12DC180	A	180	10	2,720	180	10,7	110	369	1 249,20
12DC200	A	200	16	3,850	200	11,9	116	402	1 522,50
12DC225	A	225	15	4,813	225	13,4	125	436	1 832,50
12DC250	A	250	12	5,983	250	14,8	135	462	3 973,90
12DC280	A	280	8	7,188	280	16,6	140	520	6 854,00
12DC315	A	315	4	12,850	315	18,7	160	570	8 528,90
12DC355*	B	355	3	17,800	355	21,1	210	700	15 794,60
12DC400*	B	400	4	23,500	400	23,7	300	860	22 626,30
12DC450*	B	450	1	-	450	26,7	300	960	29 478,90
12DC500*	B	500	1	-	500	29,7	300	980	39 735,30

* jiné rozměry na poptávku



TVAROVKY VSTŘIKOVANÉ

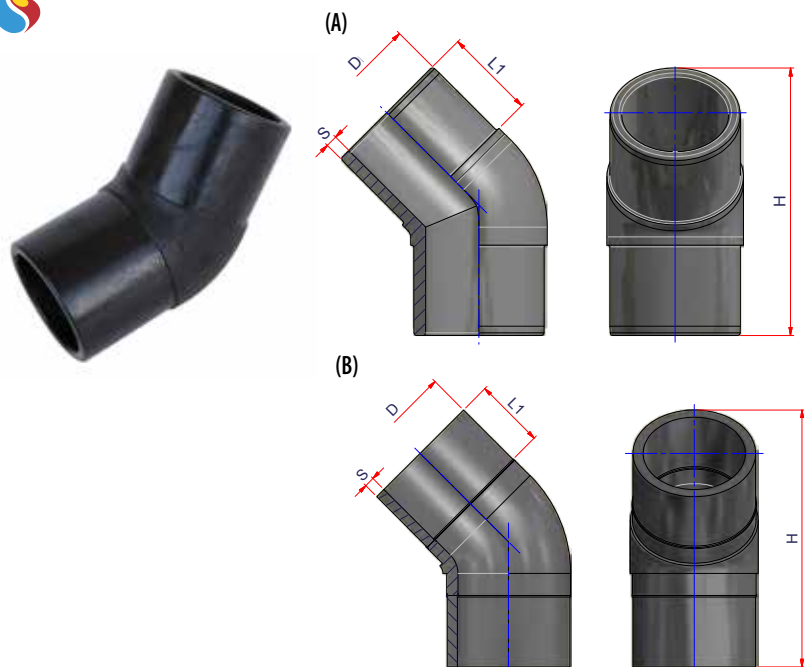

KOLENO 45° S DLOUHÝMI KONCI EC

*Krátká tvarovka s navařenými konci z PE potrubí

PE100 SDR11 PN16

slevová skupina "B"

Kód	Typ	ø	Bal.	Váha kg/ks	D, OD	S	L1	H	Cena CZK/ks
12EC032	A	32	30	0,047	32	3	50	150	124,40
12EC040	A	40	35	0,090	40	3,7	57	160	130,80
12EC050	A	50	20	0,130	50	4,6	58	170	174,40
12EC063	A	63	60	0,227	63	5,8	69	175	285,70
12EC075	A	75	20	0,348	75	6,8	73	225	341,90
12EC090	A	90	25	0,630	90	8,2	89	235	373,00
12EC110	A	110	12	0,933	110	10	86	242	496,80
12EC125	A	125	10	1,315	125	11,4	94	264,5	723,40
12EC140	A	140	8	1,738	140	12,7	96	287	1 055,50
12EC160	A	160	6	2,292	160	14,6	103	311	1 179,80
12EC180	A	180	10	3,600	180	16,4	107	369	1 441,40
12EC200	A	200	16	4,775	200	18,2	115	402	1 770,30
12EC225	A	225	15	6,440	225	20,5	120	436	2 175,10
12EC250	A	250	12	7,817	250	22,7	130	462	4 346,10
12EC280	A	280	8	11,788	280	25,4	140	520	7 965,10
12EC315	A	315	12	16,083	315	28,6	154	570	9 669,30
12EC355*	B	355	12	12,500	355	32,3	210	700	21 895,40
12EC400*	B	400	1	-	400	36,4	300	860	30 335,40
12EC450*	B	450	1	-	450	40,9	300	960	39 633,00
12EC500*	B	500	1	-	500	45,4	300	980	52 286,50

* jiné rozměry na poptávku

TVAROVKY VSTŘIKOVANÉ

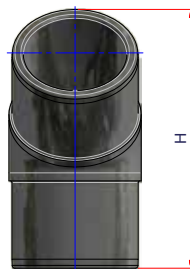
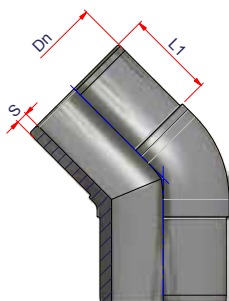

KOLENO 45° S DLOUHÝMI KONCI GC

PE100 SDR7,4 PN25

slevová skupina "B"

Kód	ø	Bal.	Váha kg/ks	Dn	S	L1	H	Cena CZK/ks
12GC063	63	-	0,378	63	8,6	69	210	549,10
12GC075	75	-	0,546	75	10,3	73	225	666,30
12GC090	90	13	0,731	90	12,3	90	235	1069,60
12GC110	110	15	1,280	110	15,1	87	242	1512,80
12GC125	125	4	2,125	125	17,1	95	264,5	3220,00
12GC140	140	-	2,730	140	19,2	97	287	4108,60
12GC160	160	-	3,561	160	21,9	102	311	4747,00
12GC180	180	-	5,429	180	24,6	110	369	7218,90
12GC200	200	9	6,167	200	27,4	116	402	7218,10
12GC225	225	10	8,400	225	30,8	125	436	10521,50
12GC250	250	12	10,658	250	34,2	135	462	13241,90
12GC280	280	-	15,600	280	38,3	140	520	21340,30
12GC315	315	4	22,175	315	43,1	155	562	23236,10

TVAROVKY VSTŘIKOVANÉ

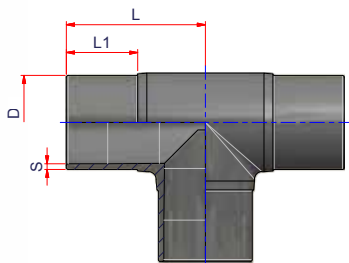

T-KUS 90° S DLOUHÝMI KONCI DT
PE100 SDR17 PN10

slevová skupina "B"

Kód	ø	Bal.	Váha kg/ks	D, OD	S	L1	L	Cena CZK/ks
12DT063	63	15	0,427	63	3,8	69	120	248,20
12DT075	75	18	0,514	75	4,5	70	117	348,40
12DT090	90	15	0,770	90	5,4	89	146	357,00
12DT110	110	9	1,333	110	6,6	87	155	455,40
12DT125	125	5	2,120	125	7,4	95	185	753,20
12DT140	140	30	2,347	140	8,3	97	195	1 086,60
12DT160	160	8	3,300	160	9,5	101	207	1 254,40
12DT180	180	7	4,400	180	10,7	110	230	1 800,90
12DT200	200	10	6,000	200	11,9	115	245	2 524,80
12DT225	225	9	7,889	225	13,4	125	275	3 011,70
12DT250	250	7	10,771	250	14,8	135	305	6 128,80
12DT280	280	3	17,733	280	16,6	140	340	9 297,60
12DT315	315	7	21,071	315	18,7	150	350	11 889,40
12DT355	355	-	-	355	21,3	166	413	17 158,80
12DT400	400	1	47,100	400	23,7	197	455	47 335,70
12DT450	450	1	56,000	450	26,7	195	485	47 842,00
12DT500	500	1	71,000	500	29,7	225	525	44 609,70

* jiné rozměry na poptávku

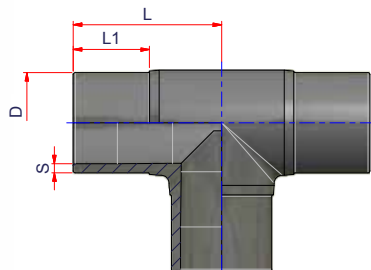
TVAROVKY VSTŘIKOVANÉ



T-KUS 90° S DLOUHÝMI KONCI ET

PE100 SDR11 PN16

slevová skupina "B"

Kód	ø	Bal.	Váha kg/ks	D, OD	S	L1	L	Cena CZK/ks
12ET025	25	20	0,050	25	3	45	70	117,40
12ET032	32	20	0,080	32	3	50	73	139,40
12ET040	40	20	0,140	40	3,7	55	85	167,10
12ET050	50	16	0,194	50	4,6	70	89	199,00
12ET063	63	30	0,430	63	5,8	69	120	273,30
12ET075	75	25	0,624	75	6,8	70	117	384,70
12ET090	90	15	0,987	90	8,2	89	146	434,70
12ET110	110	9	1,656	110	10	87	153	590,10
12ET125	125	5	2,400	125	11,4	95	185	904,70
12ET140	140	30	3,133	140	12,7	97	193	1 366,30
12ET160	160	7	4,657	160	14,6	101	207	1 614,40
12ET180	180	16	5,438	180	16,4	110	225	2 235,20
12ET200	200	10	8,050	200	18,2	115	242	3 229,30
12ET225	225	9	10,222	225	20,5	125	270	3 850,10
12ET250	250	4	15,475	250	22,7	135	300	8 487,50
12ET280	280	3	22,783	280	25,4	140	340	10 912,50
12ET315	315	7	27,771	315	28,6	150	350	16 301,00
12ET355	355	1	48,150	355	32,3	166	413	21 102,90
12ET400	400	1	62,500	400	36,3	198	470	63 152,80
12ET450	450	1	77,30	450	40,9	202	476	44 467,20
12ET500	500	1	101	500	45,4	225	525	56 651,10

* jiné rozměry na poptávku

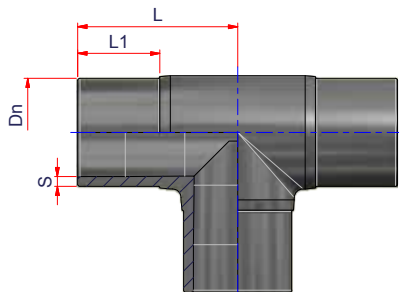

TVAROVKY VSTŘIKOVANÉ

**T-KUS 90° S DLOUHÝMI KONCI GT****PE100 SDR7,4 PN25**

slevová skupina "B"

Kód	ø	Bal.	Váha kg/ks	Dn	S	L1	L	Cena CZK/ks
12GT063	63	20	0,535	63	8,6	69	120	587,40
12GT075	75	20	0,850	75	10,3	70	117	791,00
12GT090	90	6	1,400	90	12,3	89	146	1027,60
12GT110	110	20	2,450	110	15,1	87	155	1527,00
12GT125	125	5	3,200	125	17,1	95	185	2526,00
12GT140	140	-	4,887	140	19,2	97	195	3740,50
12GT160	160	8	6,088	160	21,9	101	210	4774,80
12GT180	180	-	9,302	180	24,6	110	230	8621,90
12GT200	200	5	10,880	200	27,4	115	245	10826,40
12GT225	225	8	14,906	225	30,8	125	275	13325,30
12GT250	250	4	10,306	250	34,2	135	305	21936,70
12GT280	280	-	40,428	280	38,3	140	340	32141,10
12GT315	315	3	37,783	315	43,1	150	350	36644,00

TVAROVKY VSTŘIKOVANÉ

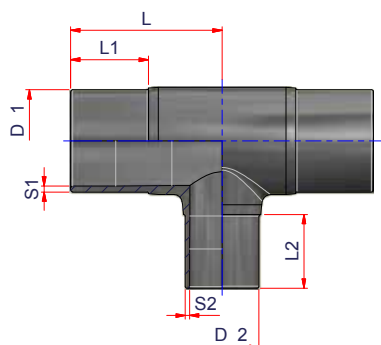

T-KUS 90° REDUKOVANÝ S DLOUHÝMI KONCI DTRS

Dle skladové dostupnosti jsou T-kusy dodávány ve dvou provedeních:
- vstříkované (jendolitě) nebo složené z t-kusu a redukce – viz obrázek.

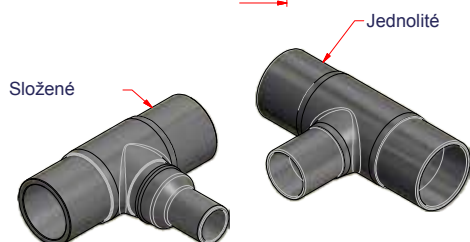

PE100 SDR17 PN10

slevová skupina "B"

Kód	ø	Bal.	Váha kg/ks	D1	S1	L1	D2	S2	L2	L	Cena CZK/ks
12DTRS9063	90 - 63	16	0,700	90	5,4	80	63	3,8	58	125	922,30
12DTRS1163	110- 63	8	1,363	110	6,6	87	63	3,8	87	155	900,10
12DTRS1190	110- 90	21	1,455	110	6,6	87	90	5,4	78	160	900,10
12DTRS1263	125- 63	-	-	125	7,4	95	63	3,8	70	185	1 286,80
12DTRS1290	125- 90	5	2,176	125	7,4	95	90	5,4	90	185	1 286,80
12DTRS1211	125-110	21	1,455	125	7,4	95	110	6,6	90	185	1 286,80
12DTRS1463	140- 63	12	2,467	140	8,3	105	63	3,8	77	193	2 018,40
12DTRS1475	140- 75	12	2,250	140	8,3	105	75	4,5	78	193	2 018,40
12DTRS1490	140- 90	14	2,264	140	8,3	105	90	5,4	87	193	2 018,40
12DTRS1411	140-110	14	2,286	140	8,3	105	110	6,6	95	193	2 018,40
12DTRS1663	160- 63	11	2,800	160	9,5	111	63	3,8	72	212	2 545,50
12DTRS1690	160- 90	8	3,388	160	9,5	111	90	5,4	84	212	2 545,50
12DTRS1611	160-110	7	3,557	160	9,5	111	110	6,6	93	212	2 545,50
12DTRS1875	180- 75	6	4,267	180	10,7	116	75	4,5	93	230	3 415,00
12DTRS1890	180- 90	6	4,517	180	10,7	116	90	5,4	84	230	3 415,00
12DTRS1811	180-110	5	4,640	180	10,7	116	110	6,6	95	230	3 415,00
12DTRS1812	180-125	6	4,683	180	10,7	116	125	7,4	100	230	3 415,00
12DTRS1814	180-140	5	4,770	180	10,7	116	140	8,3	104	230	3 415,00
12DTRS1816	180-160	5	5,040	180	10,7	116	160	9,5	110	230	3 415,00
12DTRS2011	200-110	10	5,640	200	11,9	120	110	6,6	100	261	4 284,70
12DTRS2016	200-160	5	5,330	200	11,9	120	160	9,5	100	261	4 284,70
12DTRS2290	225- 90	10	7,340	200	13,4	120	90	5,4	100	261	6 216,00
12DTRS2211	225-110	10	7,440	225	13,4	120	110	6,6	100	261	6 262,70
12DTRS2212	225-125	7	8,714	225	13,4	120	125	7,4	100	261	6 262,70

* jiné rozměry na poptávku

TVAROVKY VSTŘIKOVANÉ

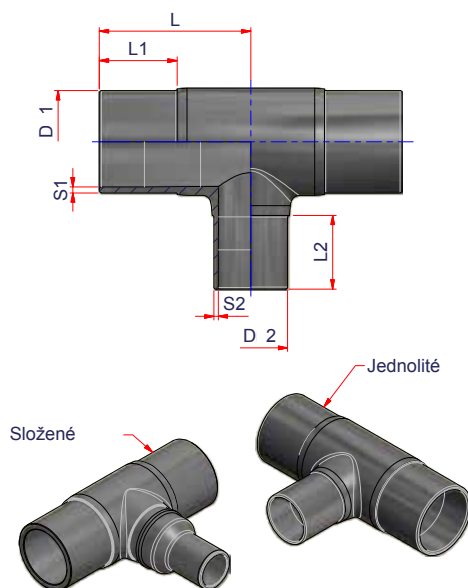

T-KUS 90° REDUKOVANÝ S DLOUHÝMI KONCI DTRS

Dle skladové dostupnosti jsou T-kusy dodávány ve dvou provedeních:
 - vstřikované (jednotlivé) nebo složené z t-kusu a redukce – viz obrázek.

PE100 SDR17 PN10

slevová skupina "B"

Kód	ø	Bal.	Váha kg/ks	D1	S1	L1	D2	S2	L2	L	Cena CZK/ks
12DTRS2216	225-160	7	7,886	225	13,4	120	160	9,5	100	261	6 262,70
12DTRS2218	225-180	2	18,300	225	13,4	120	180	10,7	100	261	6 613,60
12DTRS2511	250-110	6	9,875	250	14,8	130	110	6,6	100	340	12 511,00
12DTRS2516	250-160	5	10,720	250	14,8	130	160	9,5	110	310	12 511,00
12DTRS2811	280-110	-	-	280	16,6	150	110	6,6	170	520	17 542,10
12DTRS2822	280-225	-	-	280	16,6	-	225	13,4	-	-	17 542,10
12DTRS3111	315-110	3	19,033	315	18,7	150	110	6,6	150	360	19 877,80
12DTRS3116	315-160	9	-	315	18,7	150	160	9,5	150	360	19 877,80
12DTRS3120	315-200	3	19,833	315	18,7	150	200	11,9	150	360	19 877,80
12DTRS3122	315-225	3	19,867	315	18,7	150	225	13,4	150	360	19 877,80

* jiné rozměry na poptávku

TVAROVKY VSTŘIKOVANÉ

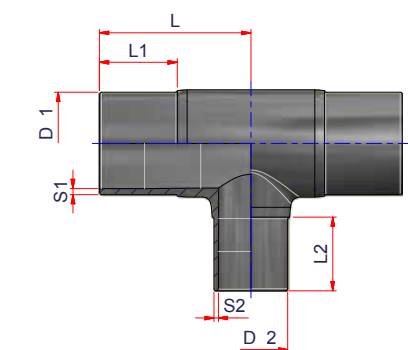

T-KUS 90° REDUKOVANÝ S DLOUHÝMI KONCI ETRS

Dle skladové dostupnosti jsou T-kusy dodávány ve dvou provedeních:
- vstříkované (jendolitě) nebo složené z t-kusu a redukce – viz obrázek.

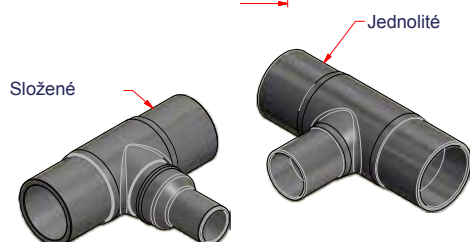

PE100 SDR11 PN16

slevová skupina "B"

Kód	ø	Bal.	Váha kg/ks	D1	S1	L1	D2	S2	L2	L	Cena CZK/ks
12ETRS6332	63-32	30	0,340	63	5,8	70	32	3	46	114	474,00
12ETRS6350	63-50	-	-	63	5,8	70	50	4,6	58	120	639,30
12ETRS7550	75-50	-	-	75	6,9	70	50	4,6	58	117	998,00
12ETRS7563	75-63	-	-	75	6,9	70	63	5,8	58	117	1014,00
12ETRS9050	90-50	15	0,833	90	8,2	80	50	4,6	70	146	964,80
12ETRS9063	90-63	15	0,883	90	8,2	80	63	5,8	58	146	964,80
12ETRS9075	90-75	-	-	90	8,2	80	75	6,9	78	146	1422,00
12ETRS1140	110-40	10	1,200	110	10	87	40	3,7	65	155	1052,90
12ETRS1150	110-50	10	1,300	110	10	87	50	4,6	70	155	1052,90
12ETRS1163	110-63	10	1,460	110	10	87	63	5,8	87	155	993,30
12ETRS1175	110-75	-	-	110	10	87	75	6,9	78	155	2232,10
12ETRS1190	110-90	10	1,430	110	10	87	90	8,2	90	155	1052,90
12ETRS1263	125-63	20	1,955	125	11,4	95	63	5,8	70	185	1476,30
12ETRS1290	125-90	15	2,107	125	11,4	95	90	8,2	90	185	1476,30
12ETRS1211	125-110	13	2,869	125	11,4	95	110	10	90	185	1476,30
12ETRS1463	140-63	15	2,600	140	12,7	105	63	5,8	77	193	2204,10
12ETRS1475	140-75	16	2,675	140	12,7	105	75	6,8	78	193	2204,10
12ETRS1490	140-90	12	2,867	140	12,7	105	90	8,2	87	193	2204,10
12ETRS1411	140-110	13	2,869	140	12,7	105	110	10	95	193	2204,10
12ETRS1663	160-63	9	3,761	160	14,6	111	63	5,8	72	212	2794,70
12ETRS1675	160-75	-	-	160	14,6	111	75	6,8	94	212	2794,70
12ETRS1690	160-90	9	3,900	160	14,6	111	90	8,2	84	212	2794,70
12ETRS1611	160-110	10	3,980	160	14,6	111	110	10	93	212	2794,70
12ETRS1875	180-75	6	5,533	180	16,4	116	75	6,8	93	230	3756,30

* jiné rozměry na poptávku



TVAROVKY VSTŘIKOVANÉ

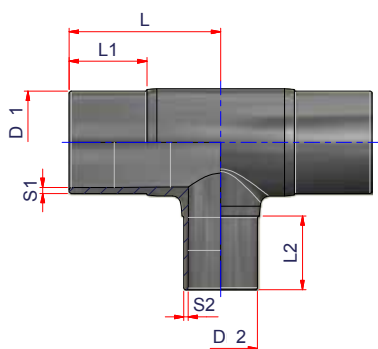

T-KUS 90° REDUKOVANÝ S DLOUHÝMI KONCI ETRS

Dle skladové dostupnosti jsou T-kusy dodávány ve dvou provedeních:
- vstříkované (jendolitě) nebo vstříkované složené z t-kusu a redukce.

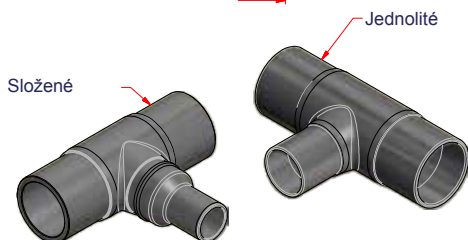

PE100 SDR1 PN16

slevová skupina "B"

Kód	ø	Bal.	Váha kg/ks	D1	S1	L1	D2	S2	L2	L	Cena CZK/ks
12ETRS1812	180-125	6	5,500	180	16,4	116	125	11,4	100	230	3 756,30
12ETRS1814	180-140	5	6,120	180	16,4	116	140	12,7	104	230	3 756,30
12ETRS1816	180-160	5	6,280	180	16,4	116	160	14,6	110	230	3 755,50
12ETRS2063	200-63	-	-	200	18,2	120	63	5,8	58	261	4 760,50
12ETRS2090	200-90	-	-	200	18,2	120	90	8,2	94	261	4 760,50
12ETRS2011	200-110	6	6,800	200	18,2	120	110	10	100	261	4 760,50
12ETRS2016	200-160	5	7,480	200	18,2	120	160	14,6	100	261	4 760,50
12ETRS2263	225-63	10	8,450	225	20,5	120	63	5,8	58	261	6 638,20
12ETRS2216	225-160	10	9,805	225	20,5	120	160	14,6	110	261	6 973,10
12ETRS2218	225-180	2	12,250	225	20,5	120	180	16,4	110	261	13 484,40
12ETRS2590	250-90	-	-	250	22,7	134	90	8,2	94	255	13 778,80
12ETRS2511	250-110	7	9,324	250	22,7	134	110	10	116	255	13 778,80
12ETRS2520	250-200	14	10,214	250	22,7	134	200	18,2	116	255	13 778,30
12ETRS2811	280-110	-	-	280	25,4	150	110	10	170	520	21 051,10
12ETRS2820	280-200	-	-	280	25,4	150	200	18,2	150	520	21 051,10
12ETRS2822	280-225	-	-	280	25,4	150	225	20,5	120	520	21 051,10
12ETRS2825	280-250	-	-	280	25,4	150	250	22,7	170	520	21 051,10
12ETRS3190	315-90	-	-	315	28,6	150	90	8,2	150	360	22 103,90
12ETRS3111	315-110	3	24,867	315	28,6	150	110	10	150	360	22 103,90
12ETRS3116	315-160	9	25,667	315	28,6	150	160	14,6	105	360	22 103,90
12ETRS3118	315-180	-	-	315	28,6	150	180	16,4	110	360	22 103,90
12ETRS3120	315-200	3	25,383	315	28,6	150	200	18,2	150	360	22 103,90
12ETRS3122	315-225	3	25,683	315	28,6	150	225	20,5	150	360	22 103,90

* jiné rozměry na poptávku

TVAROVKY VSTŘIKOVANÉ

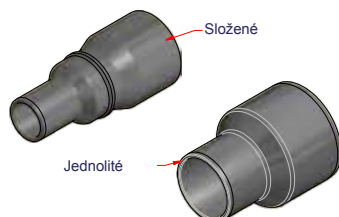
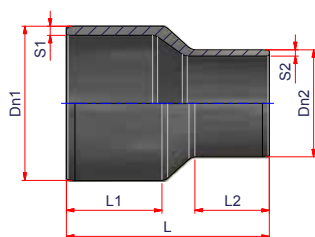

REDUKCE S DLOUHÝMI KONCI DRD

Dle skladové dostupnosti jsou redukce dodávány ve dvou provedeních:
- vstřikované (jendolitě) nebo složené - viz obrázek.

PE100 SDR17 PN10

slevová skupina "B"

Kód	ø	Bal.	Váha kg/ks	D1	S1	L1	D2	S2	L2	L	Cena CZK/ks
12DRD7563	75-63	14	0,157	75	4,5	66	63	3,8	44	140	146,90
12DRD9050	90-50	12	0,208	90	5,4	73	50	3	58	151	233,90
12DRD9063	90-63	12	0,225	90	5,4	73	63	3,8	55	148	233,90
12DRD9075	90-75	9	0,356	90	5,4	78	75	4,5	72	174	233,90
12DRD1163	110-63	6	0,360	110	6,6	84	63	3,8	63	171	322,00
12DRD1175	110-75	6	0,400	110	6,6	86	75	4,5	57	183	322,00
12DRD1190	110-90	6	0,338	110	6,6	76	90	5,4	68	171	322,00
12DRD1263	125-63	30	0,433	125	7,4	87	63	3,8	55	183	377,70
12DRD1275	125-75	18	0,456	125	7,4	90	75	4,5	60	195	377,70
12DRD1290	125-90	30	0,483	125	7,4	85	90	5,4	69	183	377,70
12DRD1211	125-110	20	0,450	125	7,4	88	110	6,6	75	185	377,70
12DRD1490	140-90	20	0,690	140	8,3	102	90	5,4	90	220	738,20
12DRD1411	140-110	16	0,713	140	8,3	95	110	6,6	85	205	738,20
12DRD1412	140-125	15	0,760	140	8,3	92	125	7,4	90	205	738,20
12DRD1690	160-90	12	0,917	160	9,5	105	90	5,4	90	225	751,90
12DRD1611	160-110	12	0,967	160	9,5	103	110	6,6	88	215	751,90
12DRD1612	160-125	12	0,996	160	9,5	102	125	7,4	91	214	751,90
12DRD1614	160-140	8	1,075	160	9,5	100	140	8,3	94	212	751,90
12DRD1890	180-90	24	1,367	180	10,7	107	90	5,4	90	-	919,00
12DRD1812	180-125	30	1,267	180	10,7	112	125	7,4	90	242	919,00
12DRD1814	180-140	-	1,200	180	10,7	100	140	8,3	82	218	919,00
12DRD1816	180-160	20	1,460	180	10,7	107	160	9,5	100	222	919,00
12DRD2014	200-140	6	1,517	200	11,9	110	140	8,3	100	240	1 427,90
12DRD2016	200-160	18	1,633	200	11,9	100,5	160	9,5	94	237,5	1 428,40
12DRD2018	200-180	12	2,133	200	11,9	113,5	180	10,7	108,5	235	1 428,40
12DRD2216	225-160	16	2,181	225	13,4	122	160	9,5	100	252	1 924,40
12DRD2218	225-180	16	2,263	225	13,4	122	180	10,7	107	252	1 924,40

* jiné rozměry na poptávku



TVAROVKY VSTŘIKOVANÉ

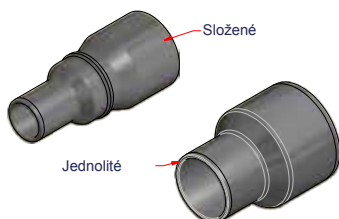
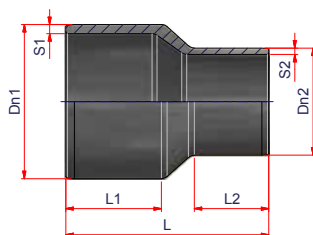

REDUKCE S DLOUHÝMI KONCI DRD

Dle skladové dostupnosti jsou redukce dodávány ve dvou provedeních:
- vstříkované (jendolitě) nebo složené - viz obrázek.

PE100 SDR17 PN10

slevová skupina "B"

Kód	ø	Bal.	Váha kg/ks	D1	S1	L1	D2	S2	L2	L	Cena CZK/ks
12DRD2220	225-200	12	2,417	225	13,4	121	200	11,9	113	255	1 924,40
12DRD2518	250-180	12	3,166	250	14,8	130	180	10,7	105	280	2 608,20
12DRD2520	250-200	8	4,563	250	14,8	130	200	11,9	115	280	2 608,20
12DRD2522	250-225	6	4,867	250	14,8	130	225	13,4	121	268	2 608,20
12DRD2820	280-200	6	4,233	280	16,6	142	200	11,9	115	292	3 569,80
12DRD2822	280-225	5	5,960	280	16,6	142	225	13,4	123	295	3 569,80
12DRD2825	280-250	5	5,840	280	16,6	140	250	14,8	130	287	3 569,80
12DRD3122	315-225	4	5,250	315	18,7	152	225	13,4	122	305	3 850,10
12DRD3125	315-250	9	5,600	315	18,7	152	250	14,8	131	305	3 850,10
12DRD3128	315-280	6	6,133	315	18,7	152	280	16,6	141	315	3 850,10
12DRD3525	355-250	6	10,317	355	21,1	170	250	14,8	132	358	8 684,30
12DRD3528	355-280	6	10,717	355	21,1	170	280	16,6	142	-	8 684,30
12DRD3531	355-315	6	11,917	355	21,1	170	315	18,7	155	-	8 684,30
12DRD4028	400-280	6	13,000	400	23,7	187	280	16,6	153	450	10 139,40
12DRD4031	400-315	4	15,375	400	23,7	185	315	18,7	160	400	10 139,40

* jiné rozměry na poptávku

TVAROVKY VSTŘIKOVANÉ

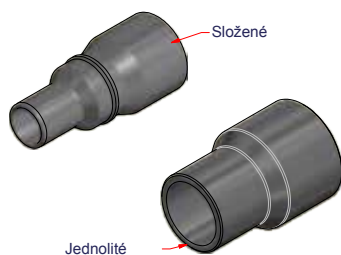
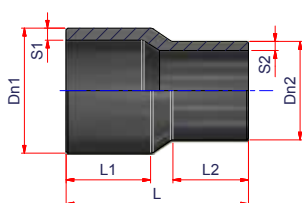

REDUKCE S DLOUHÝMI KONCI ERD

Dle skladové dostupnosti jsou redukce dodávány ve dvou provedeních:
- vstříkované (jendolité) nebo složené - viz obrázek.

PE100 SDR11 PN16

slevová skupina "B"

Kód	ø	Bal.	Váha kg/ks	D1	S1	L1	D2	S2	L2	L	Cena CZK/ks
12ERD3225	32-25	30	0,022	32	3	45	25	3	35	88	72,60
12ERD4025	40-25	54	0,039	40	3,7	50	25	3	45	100	112,20
12ERD4032	40-32	60	0,042	40	3,7	49	32	3	43	100	112,20
12ERD5025	50-25	30	0,063	50	4,6	55	25	3	45	110	123,90
12ERD5032	50-32	60	0,063	50	4,6	57	32	3	41	113	123,90
12ERD5040	50-40	30	0,083	50	4,6	57	40	3,7	49	110	123,90
12ERD6325	63-25	18	0,111	63	5,8	65	25	3	45	133	131,60
12ERD6332	63-32	30	0,113	63	5,8	57	32	3	44	129	131,60
12ERD6340	63-40	16	0,094	63	5,8	57,5	40	3,7	47	122	131,60
12ERD6350	63-50	16	0,125	63	5,8	60	50	4,6	54	139	131,60
12ERD7532	75-32	10	0,179	75	6,8	74	32	3	50	150	189,10
12ERD7540	75-40	20	0,160	75	6,8	64	40	3,7	51	140	189,10
12ERD7550	75-50	16	0,194	75	6,8	64	50	4,6	48	140	189,10
12ERD7563	75-63	14	0,221	75	6,8	66	63	5,8	44	140	189,10
12ERD9050	90-50	12	0,267	90	8,2	73	50	4,6	58	151	229,30
12ERD9063	90-63	12	0,329	90	8,2	73	63	5,8	55	148	229,30
12ERD9075	90-75	9	0,400	90	8,2	78	75	6,8	72	174	229,30
12ERD1150	110-50	6	0,467	110	10	90	50	4,6	55	178	353,60
12ERD1163	110-63	6	0,475	110	10	85	63	5,8	64	175	353,60
12ERD1175	110-75	6	0,517	110	10	86	75	6,8	57	183	353,60
12ERD1190	110-90	6	0,525	110	10	76	90	8,2	68	171	353,60
12ERD1263	125-63	24	0,567	125	11,4	87	63	5,8	55	185	403,60
12ERD1275	125-75	20	0,650	125	11,4	90	75	6,8	60	195	403,60
12ERD1290	125-90	26	0,469	125	11,4	85	90	8,2	69	183	403,60
12ERD1211	125-110	20	0,730	125	11,4	89	110	10	80	185	403,60
12ERD1490	140-90	16	0,963	140	12,7	102	90	8,2	90	220	826,30
12ERD1411	140-110	16	0,947	140	12,7	95	110	10	85	205	826,30
12ERD1412	140-125	15	1,053	140	12,7	92	125	11,4	90	205	814,10

* jiné rozměry na poptávku

TVAROVKY VSTŘIKOVANÉ

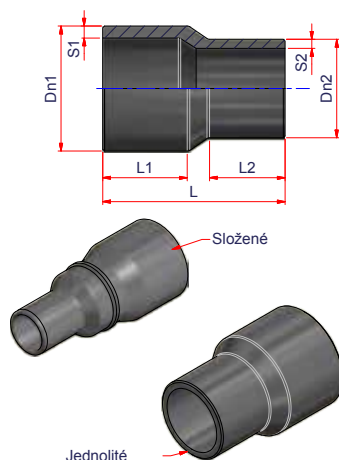

REDUKCE S DLOUHÝMI KONCI ERD

Dle skladové dostupnosti jsou redukce dodávány ve dvou provedeních:
- vstříkované (jendolitě) nebo složené - viz obrázek.

PE100 SDR11 PN16

slevová skupina "B"

Kód	ø	Bal.	Váha kg/ks	D1	S1	L1	D2	S2	L2	L	Cena CZK/ks
12ERD1690	160-90	12	1,250	160	14,6	108	90	8,2	90	230	931,90
12ERD1611	160-110	12	1,275	160	14,6	103	110	10	88	215	931,90
12ERD1612	160-125	12	1,292	160	14,6	102	125	11,4	91	214	931,90
12ERD1614	160-140	10	1,420	160	14,6	100	140	12,7	94	212	931,90
12ERD1812	180-125	24	1,721	180	16,4	107	125	11,4	90	218	956,50
12ERD1814	180-140	10	1,580	180	16,4	100	140	12,7	82	-	956,50
12ERD1816	180-160	22	1,641	180	16,4	107	160	14,6	100	222	956,50
12ERD2014	200-140	16	2,219	200	18,2	110	140	12,7	100	240	1 459,00
12ERD2016	200-160	18	2,361	200	18,2	118	160	14,6	101	240	1 459,00
12ERD2018	200-180	12	2,517	200	18,2	113,5	180	16,4	108,5	237	1 459,00
12ERD2216	225-160	16	3,100	225	20,5	122	160	14,6	100	252	2 173,80
12ERD2218	225-180	12	3,246	225	20,5	122	180	16,4	107	252	2 173,80
12ERD2220	225-200	12	3,417	225	20,5	121	200	18,2	113	255	2 173,80
12ERD2518	250-180	8	4,700	250	22,7	130	180	16,4	105	280	3 042,80
12ERD2520	250-200	8	4,563	250	22,7	130	200	18,2	115	280	3 042,80
12ERD2522	250-225	6	4,633	250	22,7	125	225	20,5	120	255	3 042,80
12ERD2820	280-200	6	6,233	280	25,4	142	200	18,2	115	292	4 036,00
12ERD2822	280-225	5	5,840	280	25,4	142	225	20,5	123	295	4 036,00
12ERD2825	280-250	5	7,300	280	25,4	140	250	22,7	130	287	4 036,00
12ERD3122	315-225	9	7,444	315	28,6	152	225	20,5	122	305	4 498,90
12ERD3125	315-250	9	7,667	315	28,6	152	250	22,7	131	305	4 498,90
12ERD3128	315-280	9	8,156	315	28,6	152	280	25,4	141	315	4 498,90
12ERD3525	350-250	6	11,558	355	32,3	172	250	22,7	146	-	9 648,60
12ERD3528	350-280	6	12,658	355	32,3	170	280	25,4	142	358	9 648,60
12ERD3531	350-315	6	11,917	355	32,3	170	315	28,6	155	360	9 648,60
12ERD4028	400-280	6	15,833	400	36,4	185	280	25,4	153	450	11 402,50
12ERD4031	400-315	6	16,667	400	36,4	185	315	28,6	160	400	11 402,50

* jiné rozměry na poptávku

TVAROVKY VSTŘIKOVANÉ

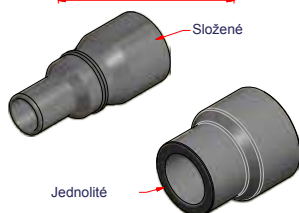
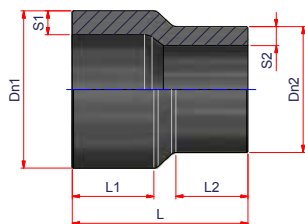

REDUKCE S DLOUHÝMI KONCI GRD

Dle skladové dostupnosti jsou redukce dodávány ve dvou provedeních:
- vstříkované (jendolitě) nebo složené - viz obrázek.

PE100 SDR7,4 PN25

slevová skupina "B"

Kód	ø	Bal.	Váha kg/ks	Dn1	S1	L1	Dn2	S2	L2	L	Cena CZK/ks
12GRD6332	63-32	24	0,158	63	8,6	-	32	4,4	-	-	350,10
12GRD7563	75-63	-	-	75	10,3	66	63	8,6	44	140	447,00
12GRD9050	90-50	-	-	90	12,3	73	50	6,9	58	151	617,50
12GRD9063	90-63	24	0,400	90	12,3	73	63	8,6	55	148	617,50
12GRD9075	90-75	-	-	90	12,3	78	75	10,3	72	174	617,50
12GRD1163	110-63	16	0,638	110	15,1	85	63	8,6	64	175	823,30
12GRD1175	110-75	30	0,683	110	15,1	86	75	10,3	57	183	823,30
12GRD1190	110-90	26	0,738	110	15,1	76	90	12,3	68	171	823,30
12GRD1250	125-50	-	-	125	17,1	-	50	6,9	-	-	1093,70
12GRD1263	125-63	-	-	125	17,1	87	63	8,6	55	185	1093,70
12GRD1275	125-75	-	-	125	17,1	90	75	10,3	60	195	1093,70
12GRD1290	125-90	-	-	125	17,1	85	90	12,3	69	183	1093,70
12GRD1211	125-110	-	-	125	17,1	89	110	15,1	80	185	1093,70
12GRD1490	140-90	-	-	140	19,2	102	90	12,3	90	220	1740,30
12GRD1411	140-110	-	-	140	19,2	95	110	15,1	85	205	1740,30
12GRD1412	140-125	-	-	140	19,2	92	125	17,1	90	205	1740,30
12GRD1690	160-90	-	-	160	21,9	108	90	12,3	90	230	1935,60
12GRD1611	160-110	12	1,750	160	21,9	103	110	15,1	88	215	1935,60
12GRD1612	160-125	-	-	160	21,9	102	125	17,1	91	214	1935,60
12GRD1614	160-140	-	-	160	21,9	100	140	19,2	94	212	1935,60
12GRD1890	180-90	-	-	180	24,6	107	90	12,3	90	260	2468,90
12GRD1812	180-125	-	-	180	24,6	107	125	17,1	90	225	2468,90
12GRD1814	180-140	-	-	180	24,6	100	140	19,2	82	218	2468,90
12GRD1816	180-160	6	2,783	180	24,6	107	160	21,9	100	222	2468,90
12GRD2014	200-140	-	-	200	27,4	110	140	19,2	100	240	3254,60
12GRD2016	200-160	16	3,150	200	27,4	118	160	21,9	101	240	3254,60
12GRD2018	200-180	-	-	200	27,4	113,5	180	24,6	108,5	237	3254,60
12GRD2216	225-160	-	-	225	30,8	122	160	21,9	100	252	3927,60
12GRD2218	225-180	-	-	225	30,8	122	180	24,6	107	252	3927,60



TVAROVKY VSTŘIKOVANÉ

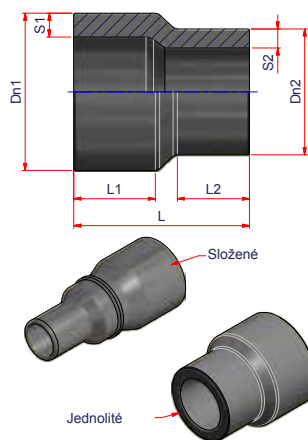

REDUKCE S DLOUHÝMI KONCI GRD

Dle skladové dostupnosti jsou redukce dodávány ve dvou provedeních:
- vstřikované (jendolitě) nebo složené - viz obrázek.

PE100 SDR7,4 PN25

slevová skupina "B"

Kód	ø	Bal.	Váha kg/ks	Dn1	S1	L1	Dn2	S2	L2	L	Cena CZK/ks
12GRD2220	225-200	-	-	225	30,8	121	200	27,4	113	255	3927,60
12GRD2518	250-180	-	-	250	34,2	130	180	24,6	105	280	5611,50
12GRD2520	250-200	-	-	250	34,2	130	200	27,4	115	280	5611,50
12GRD2522	250-225	-	-	250	34,2	125	225	30,8	120	255	5611,50
12GRD2822	280-225	-	-	280	38,3	142	225	30,8	123	295	7013,80
12GRD2825	280-250	-	-	280	38,3	140	250	34,2	130	287	7013,80
12GRD3125	315-250	-	-	315	43,1	152	250	34,2	131	305	8276,40
12GRD3128	315-280	-	-	315	43,1	152	280	38,3	141	315	8276,40
12GRD3525	355-250	-	-	355	48,5	172	250	34,2	146	415	9679,50
12GRD3528	355-280	-	-	355	48,5	170	280	38,3	142	358	9679,50
12GRD3531	355-315	-	-	355	48,5	170	315	43,1	155	360	9679,50
12GRD4035	400-355	-	-	400	54,7	185	355	48,5	170	400	14027,60

TVAROVKY VSTŘIKOVANÉ

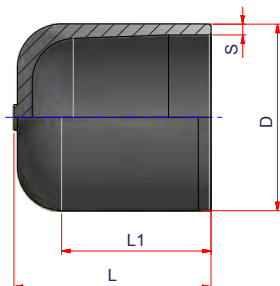

VÍČKO S DLOUHÝM KONCEM DCAL

PE100 SDR17 PN10

slevová skupina "B"

Kód	ø	Bal.	Váha kg/ks	D	S	L1	L	Cena CZK/ks
12DCAL063	63	30	0,087	63	3,8	68	87	158,00
12DCAL075	75	20	0,085	75	4,5	74	95	205,40
12DCAL090	90	18	0,211	90	5,4	83	105	338,00
12DCAL110	110	6	0,383	110	6,6	87	116	459,30
12DCAL125	125	4	0,525	125	7,4	95	128	496,00
12DCAL140	140	22	0,582	140	8,3	100	116	755,80
12DCAL160	160	16	0,875	160	9,5	108	142	755,80
12DCAL180	180	12	0,950	180	10,7	115	113	902,10
12DCAL200	200	4	1,613	200	11,9	133	169	1 146,10
12DCAL225	225	24	1,750	225	13,4	-	145	1 971,00
12DCAL250	250	18	2,236	250	14,8	-	150	2 283,90
12DCAL280	280	2	4,300	280	16,6	-	117	3 251,80
12DCAL315	315	16	4,756	315	18,7	-	208	4 451,70
12DCAL355	355	2	13,750	355	21,3	-	245	7 182,90
12DCAL400	400	2	9,900	400	23,7	-	300	12 675,00
12DCAL450*	450	1	-	450	26,7	-	-	27 630,20
12DCAL500*	500	1	-	500	29,7	-	-	31 313,10
12DCAL560*	560	1	-	560	33,2	-	-	34 997,40
12DCAL630*	630	1	-	630	37,4	-	-	38 680,40

* jiné rozměry na poptávku

TVAROVKY VSTŘIKOVANÉ

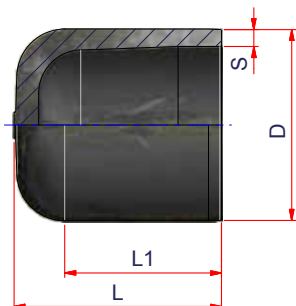

VÍČKO S DLOUHÝM KONCEM ECAL
PE100 SDR11 PN16

slevová skupina "B"

Kód	ø	Bal.	Váha kg/ks	D	S	L1	L	Cena CZK/ks
12ECAL020	20	250	0,010	20	3	50	56	88,10
12ECAL025	25	150	0,015	25	3	50	57	104,90
12ECAL032	32	200	0,019	32	3	50	59	123,10
12ECAL040	40	100	0,036	40	3,7	55	66	140,70
12ECAL050	50	70	0,057	50	4,6	60	74	158,00
12ECAL063	63	30	0,118	63	5,8	70	87	175,70
12ECAL075	75	20	0,183	75	6,8	75	95	226,20
12ECAL090	90	18	0,294	90	8,2	81	105	347,10
12ECAL110	110	40	0,464	110	10	90	119	471,40
12ECAL125	125	27	0,654	125	11,4	95	128	517,50
12ECAL140	140	24	0,777	140	12,7	100	116	811,50
12ECAL160	160	16	1,197	160	14,6	108	142	840,50
12ECAL180	180	15	1,333	180	16,4	95	113	967,40
12ECAL200	200	4	2,250	200	18,2	133	172	1 315,80
12ECAL225	225	5	2,840	225	20,5	-	145	2 002,90
12ECAL250	250	5	3,200	250	22,7	-	150	2 283,90
12ECAL280	280	2	5,800	280	25,4	-	117	3 251,80
12ECAL315	315	6	6,708	315	28,6	-	208	4 451,70
12ECAL355	355	4	9,700	355	32,3	-	245	7 182,90
12ECAL400	400	4	19,750	400	36,4	-	300	12 675,00
12ECAL450	450	1	-	450	40,9	-	-	31 313,10
12ECAL500	500	5	23,800	500	45,5	-	-	34 997,40
12ECAL560	560	1	-	560	50,9	-	-	38 681,20
12ECAL630	630	1	-	630	57,3	-	-	42 365,50

* jiné rozměry na poptávku

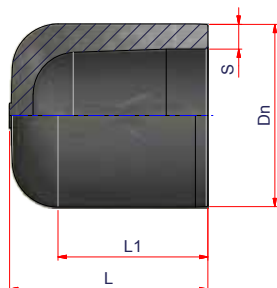
TVAROVKY VSTŘIKOVANÉ



VÍČKO S DLOUHÝM KONCEM GCAL

PE100 SDR7,4 PN25

slevová skupina "B"

Kód	ø	Bal.	Váha kg/ks	Dn	S	L1	L	Cena CZK/ks
12GCAL063	63	30	0,113	63	8,6	70	87	499,50
12GCAL075	75	20	0,180	75	10,3	75	95	771,40
12GCAL090	90	36	0,317	90	12,3	81	105	1165,80
12GCAL110	110	24	0,525	110	15,1	90	119	1566,10
12GCAL125	125	4	0,700	125	17,1	95	128	1788,40
12GCAL140	140	24	0,771	140	19,2	100	116	2665,00
12GCAL160	160	16	1,213	160	21,9	108	142	2698,00
12GCAL180	180	15	1,333	180	24,6	95	113	3752,50
12GCAL200	200	4	2,250	200	27,4	133	172	3964,40
12GCAL225	225	6	2,433	225	30,8	-	145	5050,40
12GCAL250	250	5	3,280	250	34,2	-	150	5611,50
12GCAL280	280	2	5,900	280	38,3	-	117	8522,00
12GCAL315	315	6	6,683	315	43,1	-	208	11748,80
12GCAL355	355	1	9,600	355	48,5	-	245	12098,80
12GCAL400	400	2	15,100	400	54,7	-	300	22795,20
12GCAL450*	450	1	-	450	61,5	-	-	36822,70



TVAROVKY VSTŘIKOVANÉ

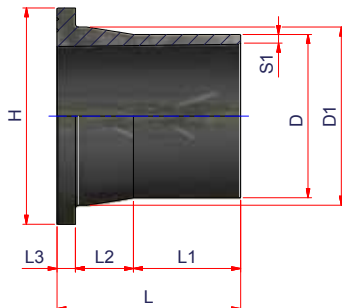

LEMOVÝ NÁKRUŽEK S DLOUHÝM KONCEM DCRT

PE100 SDR17 PN10

slevová skupina "B"

Kód	ø	Bal.	Váha kg/ks	D	S1	L1	D1	L2	L3	L	H	Cena CZK/ks
12DCRT063	63	30	0,193	63	3,8	70	75	21	14	105	102	130,80
12DCRT075	75	20	0,330	75	4,5	89	89	21	16	126	122	169,70
12DCRT090	90	30	0,427	90	5,4	113	105	21	17	141	138	221,50
12DCRT110	110	48	0,696	110	6,6	114	125	26	18	158	158	255,20
12DCRT125	125	40	0,740	125	7,4	132	132	21	18	171	158	302,60
12DCRT140	140	30	1,067	140	8,3	100	155	62	18	180	188	402,80
12DCRT160	160	24	1,358	160	9,5	105	175	46	18	180	212	449,40
12DCRT180	180	24	1,358	180	10,7	114	180	46	20	180	212	736,90
12DCRT200	200	12	2,583	200	11,9	120	232	56	24	200	268	815,40
12DCRT225	225	12	2,567	225	13,4	125	235	51	24	200	268	959,10
12DCRT250	250	18	3,594	250	14,8	142	285	40	25	207	320	1 490,60
12DCRT280	280	16	4,475	280	16,6	152	291	30	25	207	320	2 153,60
12DCRT315	315	12	5,229	315	18,7	152	335	40	25	217	370	2 812,80
12DCRT355	355	8	7,875	355	21,1	176	373	40	30	246	430	4 920,50
12DCRT400	400	5	11,080	400	23,7	182	427	45	33	260	482	7 978,50
12DCRT450	450	2	20,575	450	26,7	200	514	60	46	306	585	14 491,30
12DCRT500	500	2	22,000	500	29,7	214	530	50	46	310	585	14 735,90
12DCRT560	560	1	-	560	33,2	235	615	40	50	325	685	16 834,50
12DCRT630	630	1	-	630	37,4	255	642	40	50	345	685	21 110,60

* jiné rozměry na poptávku

TVAROVKY VSTŘIKOVANÉ

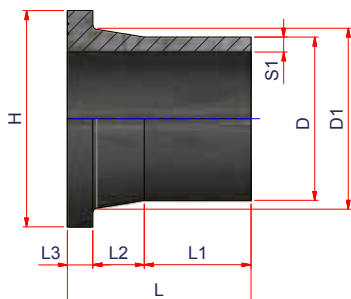

LEMOVÝ NÁKRUŽEK S DLOUHÝM KONCEM ECRT

PE100 SDR11 PN16

slevová skupina "B"

Kód	ø	Bal.	Váha kg/ks	D	S1	L1	D1	L2	L3	L	H	Cena CZK/ks
12ECRT025	25	90	0,049	25	3	42	33	27	9	78	58	46,70
12ECRT032	32	60	0,065	32	3	45	40	23	10	78	68	56,50
12ECRT040	40	30	0,093	40	3,7	63	50	21	11	95	78	64,80
12ECRT050	50	24	0,133	50	4,6	65	61	19	12	96	88	84,20
12ECRT063	63	30	0,213	63	5,8	75	75	26	14	116	102	149,00
12ECRT075	75	20	0,340	75	6,8	84	89	22	16	122	122	174,40
12ECRT090	90	30	0,547	90	8,2	100	105	37,5	17	154,5	138	233,10
12ECRT110	110	48	0,792	110	10	98,5	125	33,5	18	150	158	279,30
12ECRT125	125	40	0,785	125	11,4	122	132	31	25	178	158	326,40
12ECRT140	140	30	1,380	140	12,7	101	155	50	25	176	188	425,60
12ECRT160	160	24	1,783	160	14,6	105	175	50	25	180	212	470,90
12ECRT180	180	24	2,033	180	16,4	110	180	40	30	180	212	790,80
12ECRT200	200	12	3,367	200	18,2	125	232	43	32	200	268	837,40
12ECRT225	225	12	3,483	225	20,5	128	235	40	32	200	268	1 021,30
12ECRT250	250	18	4,978	250	22,7	132	285	40	35	207	320	1 823,40
12ECRT280	280	16	5,806	280	25,4	141	291	30	35	207	320	2 410,00
12ECRT315	315	12	7,529	315	28,6	152	335	40	35	228	370	3 060,10
12ECRT355	355	8	10,750	355	32,3	166	373	40	40	246	430	5 287,50
12ECRT400	400	5	16,200	400	36,4	182	427	45	46	274	482	9 333,90
12ECRT450	450	2	27,500	450	40,9	200	514	60	60	320	585	12580,40
12ECRT500	500	2	30,500	500	45,5	390	530	85	60	535	585	16855,70
12ECRT560	560	1	-	560	50,9	450	615	50	80	560	685	17428,10
12ECRT630	630	1	-	630	57,3	270	642	36	64	370	685	24 575,22

* jiné rozměry na poptávku



TVAROVKY VSTŘIKOVANÉ

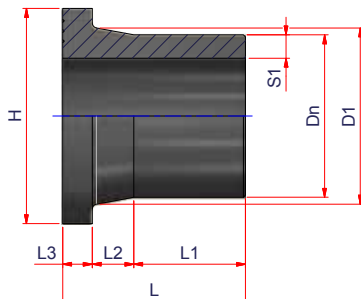

LEMOVÝ NÁKRUŽEK S DLOUHÝM KONCEM GCRT

PE100 SDR7,4 PN25

slevová skupina "B"

Kód	ø	Bal.	Váha kg/ks	Dn	S1	L1	D1	L2	L3	L	H	Cena CZK/ks
12GCRT063	63	36	0,317	63	8,6	75	75	26	14	116	102	284,70
12GCRT075	75	-	-	75	10,3	84	89	22	16	122	122	334,30
12GCRT090	90	24	0,642	90	12,3	100	105	37,5	17	154,5	138	417,70
12GCRT110	110	20	0,965	110	15,1	98,5	125	33,5	18	150	158	501,00
12GCRT125	125	-	-	125	17,1	122	132	31	25	178	158	667,80
12GCRT140	140	-	-	140	19,2	101	155	50	25	176	188	835,30
12GCRT160	160	24	2,192	160	21,9	110	175	41	29	180	212	1002,00
12GCRT180	180	6	2,683	180	24,6	110	180	40	30	180	212	1503,00
12GCRT200	200	12	4,358	200	27,4	125	232	43	32	200	268	1670,50
12GCRT225	225	52	4,615	225	30,8	123	235	40	38	201	268	2671,70
12GCRT250	250	8	6,800	250	34,2	132	285	40	38	210	320	3173,40
12GCRT280	280	48	2,844	280	38,3	141	291	30	35	207	320	5076,70
12GCRT315	315	-	-	315	43,1	155	335	30	40	225	370	6680,30
12GCRT355	355	-	-	355	48,5	166	373	40	40	246	430	8015,80
12GCRT400	400	12	10,058	400	54,7	182	427	45	50	277	485	14696,10
12GCRT450	450	-	-	450	61,5	200	514	60	60	320	585	17367,70

TVAROVKY VSTŘIKOVANÉ

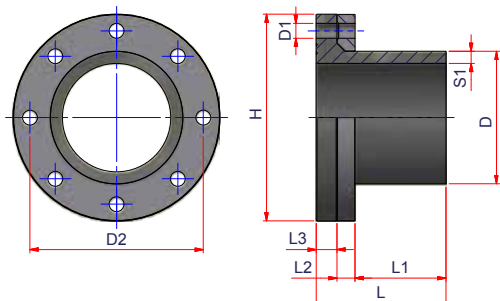

LEMOVÝ NÁKRUŽEK S INTEGROVANOU PŘÍRUBOU (DLOUHÝ KONEC) DCRTFL

PE100 SDR17 PN10

slevová skupina "B"

Kód	ø	Bal.	Dn	S1	L1	L2	L3	L	D1	D2	Otvor	H	Cena CZK/ks
12DCRTFL09065	90	1	65	5,4	85	20	17	122	18	145	8	185	7 092,20
12DCRTFL11080	110	1	80	6,6	90	20	18	128	18	160	8	200	7 735,10
12DCRTFL140100	140	1	100	8,3	100	22	18	140	18	180	8	220	8 178,00
12DCRTFL160125	160	1	125	9,5	110	22	18	150	18	210	8	250	9 265,10
12DCRTFL180150	180	1	150	10,7	115	24	20	159	22	240	8	285	10 131,50
12DCRTFL200150	200	1	150	11,9	120	24	24	168	22	240	8	285	11 585,90
12DCRTFL250200	250	1	200	14,8	140	24	25	189	22	295	12	340	14 017,80
12DCRTFL315250	315	1	250	18,7	160	26	25	211	22	350	12	395	21 052,90
12DCRTFL355300	355	1	300	21,1	175	26	30	226	22	400	12	445	21 864,80
12DCRTFL400350	400	1	350	23,7	190	30	33	253	22	460	16	505	25 677,30
12DCRTFL450400	450	1	400	26,7	205	32	46	283	26	515	16	565	32 952,60
12DCRTFL560500	560	1	500	33,2	245	38	50	333	26	620	20	670	43 821,00
12DCRTFL630600	630	1	600	37,4	265	42	50	357	30	725	20	780	84 822,50

* jiné rozměry na poptávku



OTOČNÉ PŘÍRUBY

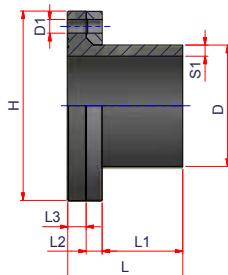
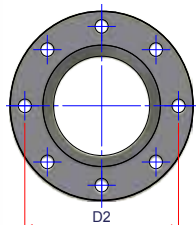

LEMOVÝ NÁKRUŽEK S INTEGROVANOU PŘÍRUBOU (DLOUHÝ KONEC) ECRTFL

PE100 SDR11 PN16

slevová skupina "B"

Kód	ø	Bal.	Dn	S1	L1	L2	L3	L	D1	D2	Otvor	H	Cena CZK/ks
12ECRTFL09065	90	1	65	8,2	85	20	17	122	18	145	8	185	7 552,00
12ECRTFL11080	110	1	80	10,0	90	20	18	128	18	160	8	200	8 233,10
12ECRTFL140100	140	1	100	12,7	100	22	25	147	18	180	8	220	8 786,60
12ECRTFL160125	160	1	125	14,6	110	22	25	157	18	210	8	250	9 920,50
12ECRTFL180150	180	1	150	16,4	115	24	30	169	22	240	8	285	10 922,70
12ECRTFL200150	200	1	150	18,2	120	24	32	176	22	240	8	285	12 580,30
12ECRTFL250200	250	1	200	22,7	140	26	35	201	22	295	12	340	15 215,00
12ECRTFL315250	315	1	250	28,6	160	29	35	224	26	355	12	405	22 656,10
12ECRTFL355300	355	1	300	32,2	175	32	40	247	26	410	12	460	23 558,70
12ECRTFL400350	400	1	350	40,1	190	35	46	271	26	470	16	520	28 016,90
12ECRTFL450400	450	1	450	45,1	205	38	60	303	30	525	16	580	35 789,30
12ECRTFL560500	560	1	500	56,0	245	46	80	371	33	650	20	715	47 503,90
12ECRTFL630600	630	1	600	63,1	265	55	80	400	36	770	20	840	87 511,70

* jiné rozměry na poptávku

OTOČNÉ PŘÍRUBY

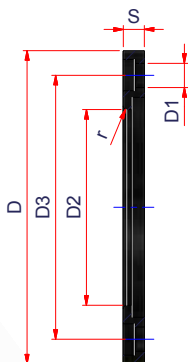

OTOČNÁ PŘÍRUBA LITINOVÁ S EPOXIDOVOU PROTIKOROZNÍ ÚPRAVOU

Charakteristika: Příklad z tvárné litiny GGG40 s černým epoxidovým nástřikem

Odolná vůči korozi

FM approved

Bezpečnostní faktor 2

Použití: K lemovým nákrůžkům z PE, PP a PVDF

Spoj: Dle norem ISO 7005, EN1092, DIN 2501

Materiál: Tvárná litina GGG40 (DIN 1693), epoxid

slevová skupina "C"

Kód	ø	Bal.	Váha kg/ks	PN	D(PE)	Dn	D	S	D2	r	D3	D1	Otvor	Šrouby	Cena CZK/ks
DF2DI 50-10/16	50x40	1	1,050	10-16	50	40	150	16	62	3	110	18	4	M16	272,00
DF2DI 63-10/16	63x50	1	1,300	10-16	63	50	165	16	78	3	125	18	4	M16	294,50
DF2DI 75-10/16	75x65	1	1,350	10-16	75	65	185	16	92	3	145	18	4	M16	373,00
DF2DI 90-10/16	90x80	1	1,750	10-16	90	80	200	19	108	3	160	18	8	M16	429,20
DF2DI 110-10/16	110x100	1	1,900	10-16	110	100	220	19	128	3	180	18	8	M16	482,60
DF2DI 125-10/16	125x100	1	1,800	10-16	125	100	220	19	135	3	180	18	8	M16	505,90
DF2DI 140-10/16	140x125	1	2,300	10-16	140	125	250	19	158	3	210	18	8	M16	594,50
DF2DI 160-10/16	160x150	1	2,950	10-16	160	150	285	19	178	3	240	22	8	M20	725,80
DF2DI 180-10/16	180x150	1	2,800	10-16	180	150	285	19	188	3	240	22	8	M20	733,50
DF2DI 200/225-10	200-225x200	1	3,750	10	200	200	340	18	238	3	295	22	8	M20	978,50
DF2DI 200/225-16	200-225x200	1	4,300	16	200	200	340	23	238	3	295	22	12	M20	1 119,70
DF2DI 250-10	250x250	1	6,550	10	250	250	395	22	288	3	350	22	12	M20	1 493,20
DF2DI 250-16	250x250	1	6,600	16	250	250	405	29	288	3	355	26	12	M24	1 853,70
DF2DI 280-10	280x250	1	5,500	10	280	250	395	22	294	3	350	22	12	M20	1 493,20
DF2DI 280-16	280x250	1	5,800	16	280	250	405	29	294	3	355	26	12	M24	1 853,70
DF2DI 315-10	315x300	1	6,650	10	315	300	445	26	338	3	400	22	12	M20	1 839,20
DF2DI 315-16	315x300	1	8,500	16	315	300	460	34	338	3	410	26	12	M24	2 347,90
DF2DI 355-10	355x350	1	11,900	10	355	350	505	30	376	4	460	22	16	M20	3 188,90
DF2DI 355-16	355x350	1	15,000	16	355	350	520	39	376	4	470	26	16	M24	4 061,40
DF2DI 400-10	400x400	1	17,400	10	400	400	565	34	430	4	515	26	16	M24	4 010,40
DF2DI 400-16	400x400	1	18,600	16	400	400	580	43	430	4	525	30	16	M27	4 807,90
DF2DI 450-10	450x500	1	22,500	10	450	500	670	42	517	6	620	26	20	M24	5 757,10
DF2DI 450-16	450x500	1	31,500	16	450	500	715	46	517	6,5	650	33	20	M30	7 478,70
DF2DI 500-10	500x500	1	23,300	10	500	500	670	38	533	4	620	26	20	M24	5 757,10
DF2DI 500-16	500x500	1	29,800	16	500	500	715	46	533	7	650	33	20	M30	7 433,10
DF2DI 560-10	560x600	1	40,000	10	560	600	785	50	618	7	725	30	20	M27	10 121,20
DF2DI 560-16	560x600	1	51,600	16	560	600	840	55	618	6	770	36	20	M33	na poptávku
DF2DI 630-10	630x600	1	26,800	10	630	600	785	40	645	4	725	30	20	M27	na poptávku
DF2DI 630-16	630x600	1	49,000	16	630	600	840	55	645	6	770	36	20	M33	na poptávku

OTOČNÉ PŘÍRUBY

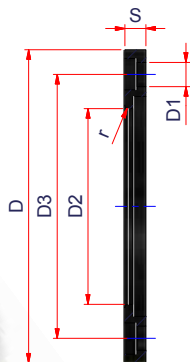

OTOČNÁ PŘÍRUBA LITINOVÁ S EPOXIDOVOU PROTIKOROZNÍ ÚPRAVOU

Charakteristika: Příklad z tvárné litiny GGG40 s černým epoxidovým nástřikem

Odolná vůči korozi

FM approved

Bezpečnostní faktor 2

Použití: K lemovým nákrůžkům z PE, PP a PVDF

Spoj: Dle norem ISO 7005, EN1092, DIN 2501

Materiál: Tvárná litina GGG40 (DIN 1693), epoxid

slevová skupina "C"

Kód	ø	Bal.	Váha kg/ks	PN	D(PE)	Dn	D	S	D2	r	D3	D1	Otvor	Šrouby	Cena CZK/ks
DF2DI 710-10	710x700	1	38,5	6	710	700	900	45	740	5	840	30	24	M27	na dopyt
DF2DI 800-10	800x800	1	56,5	6	800	800	1015	53	843	5	950	33	24	M30	na dopyt
DF2DI 900-10	900x900	1	59,6	6	900	900	1115	56	947	5	1050	33	28	M30	na dopyt
DF2DI 1000-10	1000x1000	1	75	6	1000	1000	1230	62	1050	5	1160	36	28	M33	na dopyt
DF2DI 1200-10	1200x1200	1	107	4	1200	1200	1455	68	1260	6	1380	39	32	M36	na dopyt
DF2DI 1400-10	1400x1400	1	143	4	1400	1400	1675	72	1441	6	1590	42	36	M39	na dopyt
DF2DI 1600-10	1600x1600	1	203	4	1600	1600	1915	84	1644	6	1820	48	40	M45	na dopyt



OTOČNÉ PŘÍRUBY

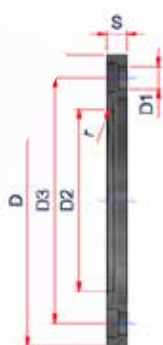

OTOČNÁ PŘÍRUBA LITINOVÁ S PP-LAMINÁTOVOU PROTIKOROZNÍ ÚPRAVOU

Charakteristika: Příklad litiny GGG40 s 30% vrstvou z PP sklolaminátu
Vysoce odolná vůči korozi

FM approved

Bezpečnostní faktor 2

Použití: K lemovým nákuřkům z PE, PP a PVDF, vhodná pro náročné aplikace vyžadující vysokou odolnost vůči korozi

Spoj: Dle norem ISO 7005, EN1092, DIN 2501

Materiál: Tvárná litina GGG40 (DIN 1693), 30% sklolaminát PP

slevová skupina "C"

Kód	ø	Bal.	Váha kg/ks	PN	D(PE)	Dn	D	S	D2	r	D3	D1	Otvor	Šrouby	Cena CZK/ks
PPDA 25-10/16	25x20	1	0,450	10-16	25	20	118	18	34	3	75	14	4	M12	184,70
PPDA 32-10/16	32x25	1	0,500	10-16	32	25	122	17	42	3	85	14	4	M12	178,00
PPDA 40-10/16	40x32	1	0,550	10-16	40	32	142	17	51	3	100	18	4	M16	222,50
PPDA 50-10/16	50x40	1	0,750	10-16	50	40	156	19	62	3	110	18	4	M16	301,80
PPDA 63-10/16	63x50	1	0,900	10-16	63	50	171	20	78	3	125	18	4	M16	304,90
PPDA 75-10/16	75x65	1	1,100	10-16	75	65	191	21	92	3	145	18	8	M16	421,20
PPDA 90-10/16	90x80	1	1,300	10-16	90	80	206	21	108	3	160	18	8	M16	429,50
PPDA 110-10/16	110x100	1	1,400	10-16	110	100	226	22	128	3	180	18	8	M16	539,30
PPDA 125-10/16	125x100	1	1,350	10-16	125	100	226	23	135	3	180	18	8	M16	573,50
PPDA 140-10/16	140x125	1	1,800	10-16	140	125	261	25	158	3	210	18	8	M16	742,60
PPDA 160-10/16	160x150	1	2,400	10-16	160	150	296	28	178	3	240	22	8	M20	811,20
PPDA 180-10/16	180x150	1	2,250	10-16	180	150	296	27	188	4	240	22	8	M20	933,20
PPDA 200/10	200x200	1	3,450	10	200	200	350	32	235	3	295	22	8	M20	1 334,70
PPDA 225/10	225x200	1	3,100	16	225	200	350	31	238	4	295	22	12	M20	1 130,10
PPDA 250-10	250x250	1	5,100	10	250	250	412	36	288	4	350	22	12	M20	1 720,30
PPDA 280-10	280x250	1	4,800	10	280	250	412	35	294	4	350	22	12	M20	1 720,30
PPDA 315-10	315x300	1	7,150	10	315	300	462	42	338	4	400	22	12	M20	2 022,60
PPDA 355-10	355x350	1	11,500	10	355	350	525	52	376	6	460	22	16	M20	4 650,40
PPDA 400-10	400x400	1	14,700	10	400	400	586	56	430	6	515	26	16	M24	5 411,60

OTOČNÉ PŘÍRUBY



OTOČNÁ PŘÍRUBA LITINOVÁ S PP-LAMINÁTOVOU PROTIKOROZNÍ ÚPRAVOU

Charakteristika: Příklad z tvárné litiny GGG40 s 30% vrstvou z PP sklolaminátu

Vysoce odolná vůči korozi

FM approved

Bezpečnostní faktor 2

Použití: K lemovým nákrůžkům z PE, PP a PVDF, vhodná pro náročné aplikace vyžadující vysokou odolnost vůči korozi

Spoj: Dle norem ISO 7005, EN1092, DIN 2501

Materiál: Tvárná litina GGG40 (DIN 1693), 30% sklolaminát PP

slevová skupina "C"

Kód	ø	Bal.	Váha kg/ks	PN	D(PE)	Dn	D	S	D2	r	D3	D1	otvor	Šrouby	Cena CZK/ks
PPDA 450-10	450x500	1	19	10	450	500	690	54,5	514		620	27	20	M24	na poptávku
PPDA 500-10	500x500	1	19	10	500	500	690	55	530		620	27	20	M24	na poptávku
PPDA 560-10	560x600	1	30	10	560	600	804	62	615		725	30	20	M27	na poptávku
PPDA 630-10	630x600	1	27,7	10	630	600	804	62	642		725	30	20	M27	na poptávku
PPDA 710-10	710x700	1	28,6	6	710	700	912	49	740	5	840	30	24	M27	na poptávku
PPDA 800-10	800x800	1	39,3	6	800	800	1026	58	843	5	950	33	24	M30	na poptávku
PPDA 900-10	900x900	1	48,5	6	900	900	1129	62	947	5	1050	33	28	M30	na poptávku
PPDA 1000-10	1000x1000	1	60	6	1000	1000	1245	70	1050	5	1160	36	28	M33	na poptávku

OTOČNÉ PŘÍRUBY

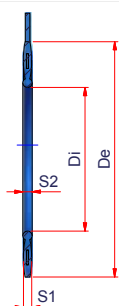

PŘÍRUBOVÉ TĚSNĚNÍ S OCELOVOU VÝZTUHOU

slevová skupina "E"

Kód	ø PE	Bal.	Váha kg/ks	DN	PN	Di	De	S1	S2	Cena CZK/ks
GSSK-0032-40	40	1	0,041	32	40	43	82	3	4	70,00
GSSK-0040-40	50	1	0,041	40	40	49	92	3	4	73,10
GSSK-0050-40	63	1	0,02	50	40	61	107	4	5	75,70
GSSK-0065-40	75	1	0,03	65	40	77	127	4	5	80,90
GSSK-0080-16	90	1	0,04	80	16	90	142	4	5	86,60
GSSK-0100-16	110-125	1	0,02	100	16	115	162	5	6	93,30
GSSK-0125-16	140	1	0,2	125	16	141	194	5	6	106,20
GSSK-0150-16	160-180	1	0,2	150	16	169	218	6	8	118,10
GSSK-0200-16	200-225	1	0,2	200	16	220	273	6	8	209,30
GSSK-0250-16	250-280	1	0,36	250	16	274	330	6	8	297,90
GSSK-0300-16	315	1	0,4	300	16	325	385	6	8	463,10
GSSK-0350-16	355	1	0,6	350	16	368	445	7	10	542,40
GSSK-0400-16	400	1	0,8	400	16	420	497	7	10	628,40
GSSK-0500-10	450-500	1	1	500	10	520	595	7	10	827,30



SEGMENTOVÁ KOLENA



Ilustrační obrázek

SEGMENTOVÉ KOLENO ÚHEL 7,5° – 30°

PE100	PE100
PN 10	PN 16
8,00 bar	12,8 bar

PE100 SDR17 PN10

Kód	Název	slevová skupina "F"
		Cena CZK/ks
SK17090075-30	Segmentové koleno SDR 17 D090, uhol 7,5 - 30	502,00
SK17110075-30	Segmentové koleno SDR 17 D110, uhol 7,5 - 30	576,30
SK17125075-30	Segmentové koleno SDR 17 D125, uhol 7,5 - 30	615,90
SK17140075-30	Segmentové koleno SDR 17 D140, uhol 7,5 - 30	656,60
SK17160075-30	Segmentové koleno SDR 17 D160, uhol 7,5 - 30	943,60
SK17180075-30	Segmentové koleno SDR 17 D180, uhol 7,5 - 30	1 019,20
SK17200075-30	Segmentové koleno SDR 17 D200, uhol 7,5 - 30	1 322,80
SK17225075-30	Segmentové koleno SDR 17 D225, uhol 7,5 - 30	1 452,50
SK17250075-30	Segmentové koleno SDR 17 D250, uhol 7,5 - 30	1 573,50

* Dimenze D315, D355, D400, D450, D560, D630, D710, D800, D900, D1000, D1200 - na poptávku

PE100 SDR11 PN16

Kód	Název	slevová skupina "F"
		Cena CZK/ks
SK11090075-30	Segmentové koleno SDR 11 D090, uhol 7,5 - 30	680,20
SK11110075-30	Segmentové koleno SDR 11 D110, uhol 7,5 - 30	745,20
SK11125075-30	Segmentové koleno SDR 11 D125, uhol 7,5 - 30	805,50
SK11140075-30	Segmentové koleno SDR 11 D140, uhol 7,5 - 30	870,00
SK11160075-30	Segmentové koleno SDR 11 D160, uhol 7,5 - 30	1 298,40
SK11180075-30	Segmentové koleno SDR 11 D180, uhol 7,5 - 30	1 416,30
SK11200075-30	Segmentové koleno SDR 11 D200, uhol 7,5 - 30	1 543,20
SK11225075-30	Segmentové koleno SDR 11 D225, uhol 7,5 - 30	1 940,50
SK11250075-30	Segmentové koleno SDR 11 D250, uhol 7,5 - 30	2 136,80

* Dimenze D315, D355, D400, D450, D560, D630 - na poptávku

SEGMENTOVÁ KOLENA



Ilustrační obrázek

SEGMENTOVÉ KOLENO ÚHEL 31° – 60°

PE100	PE100
PN 10	PN 16
8,00 bar	12,8 bar

PE 100 SDR17 PN10

slevová skupina "F"

Kód	Název	Cena CZK/ks
SK1709031-60	Segmentové koleno SDR 17 D090, uhol 31 - 60	1 017,90
SK1711031-60	Segmentové koleno SDR 17 D110, uhol 31 - 60	1 091,00
SK1712531-60	Segmentové koleno SDR 17 D125, uhol 31 - 60	1 153,10
SK1714031-60	Segmentové koleno SDR 17 D140, uhol 31 - 60	1 216,60
SK1716031-60	Segmentové koleno SDR 17 D160, uhol 31 - 60	1 760,50
SK1718031-60	Segmentové koleno SDR 17 D180, uhol 31 - 60	1 879,10
SK1720031-60	Segmentové koleno SDR 17 D200, uhol 31 - 60	2 448,60
SK1722531-60	Segmentové koleno SDR 17 D225, uhol 31 - 60	2 652,70
SK1725031-60	Segmentové koleno SDR 17 D250, uhol 31 - 60	2 972,10

PE 100 SDR11 PN16

slevová skupina "F"

Kód	Název	Cena CZK/ks
SK1109031-60	Segmentové koleno SDR 11 D090, uhol 31 - 60	1 300,00
SK1111031-60	Segmentové koleno SDR 11 D110, uhol 31 - 60	1 402,00
SK1112531-60	Segmentové koleno SDR 11 D125, uhol 31 - 60	1 497,10
SK1114031-60	Segmentové koleno SDR 11 D140, uhol 31 - 60	1 598,30
SK1116031-60	Segmentové koleno SDR 11 D160, uhol 31 - 60	2 410,60
SK1118031-60	Segmentové koleno SDR 11 D180, uhol 31 - 60	2 595,70
SK1120031-60	Segmentové koleno SDR 11 D200, uhol 31 - 60	2 795,20
SK1122531-60	Segmentové koleno SDR 11 D225, uhol 31 - 60	3 511,80
SK1125031-60	Segmentové koleno SDR 11 D250, uhol 31 - 60	3 820,30

* Dimenze D315, D355, D400, D450, D560, D630 - na poptávku

SEGMENTOVÁ KOLENA



Ilustrační obrázek

SEGMENTOVÉ KOLENO ÚHEL 61° – 90°

PE100	PE100
PN 10	PN 16
8,00 bar	12,8 bar

PE 100 SDR17 PN10

slevová skupina "F"

Kód	Název	Cena CZK/ks
SK1709061-90	Segmentové koleno SDR 17 D090, uhol 61 - 90	1 246,60
SK1711061-90	Segmentové koleno SDR 17 D110, uhol 61 - 90	1 346,30
SK1712561-90	Segmentové koleno SDR 17 D125, uhol 61 - 90	1 431,00
SK1714061-90	Segmentové koleno SDR 17 D140, uhol 61 - 90	1 517,80
SK1716061-90	Segmentové koleno SDR 17 D160, uhol 61 - 90	1 929,60
SK1718061-90	Segmentové koleno SDR 17 D180, uhol 61 - 90	2 091,50
SK1720061-90	Segmentové koleno SDR 17 D200, uhol 61 - 90	2 926,70
SK1722561-90	Segmentové koleno SDR 17 D225, uhol 61 - 90	3 205,20
SK1725061-90	Segmentové koleno SDR 17 D250, uhol 61 - 90	3 464,20

* Dimenze D315, D355, D400, D450, D560, D630, D710, D800, D900, D1000, D1200 - na poptávku

PE 100 SDR11 PN16

slevová skupina "F"

Kód	Název	Cena CZK/ks
SK1109061-90	Segmentové koleno SDR 11 D090, uhol 61 - 90	1 596,30
SK1111061-90	Segmentové koleno SDR 11 D110, uhol 61 - 90	1 735,30
SK1112561-90	Segmentové koleno SDR 11 D125, uhol 61 - 90	1 864,80
SK1114061-90	Segmentové koleno SDR 11 D140, uhol 61 - 90	2 002,90
SK1116061-90	Segmentové koleno SDR 11 D160, uhol 61 - 90	2 874,90
SK1118061-90	Segmentové koleno SDR 11 D180, uhol 61 - 90	3 127,50
SK1120061-90	Segmentové koleno SDR 11 D200, uhol 61 - 90	3 399,40
SK1122561-90	Segmentové koleno SDR 11 D225, uhol 61 - 90	4 435,40
SK1125061-90	Segmentové koleno SDR 11 D250, uhol 61 - 90	4 856,30

* Dimenze D315, D355, D400, D450, D560, D630 - na poptávku

FORMOVANÉ OBLOUKY

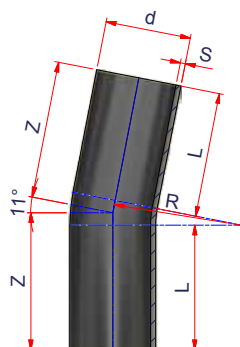

OBLOUK 11°

Rozměry L, R, Z uvedené v tabulce jsou informativní
D 710 – D 900 na vyžádání

PE100 SDR17 PN10

slevová skupina "B"

Kód	ø	Bal.	d	S	L	R	Z	Cena CZK/ks
12DCSS11110	110	1	110	6,6	160	165	176	1 804,80
12DCSS11125	125	1	125	7,4	160	187,5	178	2 035,30
12DCSS11140	140	1	140	8,3	160	210	180	2 347,40
12DCSS11160	160	1	160	9,5	160	240	183	2 575,80
12DCSS11180	180	1	180	10,7	160	270	186	4 620,60
12DCSS11200	200	1	200	11,9	160	300	189	4 992,30
12DCSS11225	225	1	225	13,4	160	337,5	192	5 907,30
12DCSS11250	250	1	250	14,8	260	375	296	7 153,10
12DCSS11280	280	1	280	16,6	260	420	300	7 912,50
12DCSS11315	315	1	315	18,7	310	472,5	355	10 212,40
12DCSS11355	355	1	355	21,1	310	532,5	361	16 134,50
12DCSS11400	400	1	400	23,7	310	600	368	22 891,20
12DCSS11450	450	1	450	26,7	310	675	375	27 558,40
12DCSS11500	500	1	500	29,7	360	750	432	39 201,00
12DCSS11560	560	1	560	32,2	400	840	481	63 604,00
12DCSS11630	630	1	630	37,4	440	945	531	79 339,00

PE100 SDR11 PN16

slevová skupina "B"

Kód	ø	Bal.	d	S	L	R	Z	Cena CZK/ks
12ECS11110	110	1	110	10	160	165	176	2 261,10
12ECS11125	125	1	125	11,4	160	187,5	178	2 522,20
12ECS11140	140	1	140	12,7	160	210	180	2 857,60
12ECS11160	160	1	160	14,6	160	240	183	3 349,70
12ECS11180	180	1	180	16,4	160	270	186	5 592,60
12ECS11200	200	1	200	18,2	160	300	189	6 784,00
12ECS11225	225	1	225	20,5	160	337,5	192	8 133,90
12ECS11250	250	1	250	22,7	260	375	296	9 490,60
12ECS11280	280	1	280	25,4	260	420	300	11 278,20
12ECS11315	315	1	315	28,6	310	472,5	355	13 685,10
12ECS11355	355	1	355	32,3	310	532,5	361	25 029,80
12ECS11400	400	1	400	36,4	310	600	368	28 045,30
12ECS11450	450	1	450	40,9	310	675	375	34 591,60
12ECS11500	500	1	500	45,5	360	750	432	50 770,50
12ECS11560	560	1	560	50,9	400	840	481	82 396,50
12ECS11630	630	1	630	57,3	440	945	531	105 888,30

* jiné rozměry na poptávku

FORMOVANÉ OBLOUKY

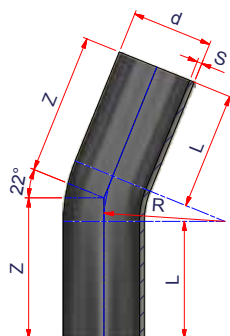

OBLOUK 22°

Rozměry L, R, Z uvedené v tabulce jsou informativní
D 710 – D 900 na vyžádání

PE100 SDR17 PN10

slevová skupina "B"

Kód	ø	Bal.	d	S	L	R	Z	Cena CZK/ks
12DCSS22110	110	1	110	6,6	160	165	192	1 804,80
12DCSS22125	125	1	125	7,4	160	187,5	196	2 035,30
12DCSS22140	140	1	140	8,3	160	210	201	2 347,40
12DCSS22160	160	1	160	9,5	160	240	207	2 575,80
12DCSS22180	180	1	180	10,7	160	270	212	4 620,60
12DCSS22200	200	1	200	11,9	160	300	218	4 992,30
12DCSS22225	225	1	225	13,4	160	337,5	226	5 907,30
12DCSS22250	250	1	250	14,8	260	375	333	7 153,10
12DCSS22280	280	1	280	16,6	260	420	342	7 912,50
12DCSS22315	315	1	315	18,7	310	472,5	402	10 212,40
12DCSS22355	355	1	355	21,1	310	532,5	414	16 134,50
12DCSS22400	400	1	400	23,7	310	600	427	22 891,20
12DCSS22450	450	1	450	26,7	310	675	441	27 558,40
12DCSS22500	500	1	500	29,7	360	750	506	39 201,00
12DCSS22560	560	1	560	32,2	400	840	563	63 604,00
12DCSS22630	630	1	630	37,4	440	945	624	79 339,00

PE100 SDR11 PN16

slevová skupina "B"

Kód	ø	Bal.	d	S	L	R	Z	Cena CZK/ks
12ECSS22110	110	1	110	10	160	165	192	2 261,10
12ECSS22125	125	1	125	11,4	160	187,5	196	2 522,20
12ECSS22140	140	1	140	12,7	160	210	201	2 857,60
12ECSS22160	160	1	160	14,6	160	240	207	3 349,70
12ECSS22180	180	1	180	16,4	160	270	212	5 592,60
12ECSS22200	200	1	200	18,2	160	300	218	6 784,00
12ECSS22225	225	1	225	20,5	160	337,5	226	8 133,90
12ECSS22250	250	1	250	22,7	260	375	333	9 490,60
12ECSS22280	280	1	280	25,4	260	420	342	11 278,20
12ECSS22315	315	1	315	28,6	310	472,5	402	13 685,10
12ECSS22355	355	1	355	32,3	310	532,5	414	25 029,80
12ECSS22400	400	1	400	36,4	310	600	427	28 045,30
12ECSS22450	450	1	450	40,9	310	675	441	34 591,60
12ECSS22500	500	1	500	45,5	360	750	506	50 770,50
12ECSS22560	560	1	560	50,9	400	840	563	82 396,50
12ECSS22630	630	1	630	57,3	440	945	624	105 888,30

* jiné rozměry na poptávku



FORMOVANÉ OBLOUKY

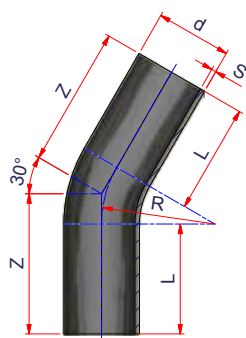

OBLOUK 30°

Rozměry L, R, Z uvedené v tabulce jsou informativní
D 710 – D 900 na vyžádání

PE100 SDR17 PN10

slevová skupina "B"

Kód	ø	Bal.	d	S	L	R	Z	Cena CZK/ks
12DCSS30110	110	1	110	6,6	150	165	330	1 804,80
12DCSS30125	125	1	125	7,4	150	188	380	2 035,30
12DCSS30140	140	1	140	8,3	150	210	400	2 347,40
12DCSS30160	160	1	160	9,5	150	240	420	2 575,80
12DCSS30180	180	1	180	10,7	150	270	450	4 620,60
12DCSS30200	200	1	200	11,9	150	300	480	4 992,30
12DCSS30225	225	1	225	13,4	150	338	520	5 907,30
12DCSS30250	250	1	250	14,8	250	375	560	7 153,10
12DCSS30280	280	1	280	16,6	250	420	530	7 912,50
12DCSS30315	315	1	315	18,7	300	473	650	10 212,40
12DCSS30355	355	1	355	21,1	300	533	650	16 134,50
12DCSS30400	400	1	400	23,7	300	600	690	22 891,20
12DCSS30450	450	1	450	26,7	300	675	730	27 558,40
12DCSS30500	500	1	500	29,7	350	750	1100	39 201,00
12DCSS30560	560	1	560	32,2	350	840	1100	63 604,00
12DCSS30630	630	1	630	37,4	350	945	1250	79 339,00

PE100 SDR11 PN16

slevová skupina "B"

Kód	ø	Bal.	d	S	L	R	Z	Cena CZK/ks
12ECSS30110	110	1	110	10	150	165	330	2 261,10
12ECSS30125	125	1	125	11,4	150	188	380	2 522,20
12ECSS30140	140	1	140	12,7	150	210	400	2 857,60
12ECSS30160	160	1	160	14,6	150	240	420	3 349,70
12ECSS30180	180	1	180	16,4	150	270	450	5 592,60
12ECSS30200	200	1	200	18,2	150	300	480	6 784,00
12ECSS30225	225	1	225	20,5	150	338	520	8 133,90
12ECSS30250	250	1	250	22,7	250	375	560	9 490,60
12ECSS30280	280	1	280	25,4	250	420	530	11 278,20
12ECSS30315	315	1	315	28,6	300	473	650	13 685,10
12ECSS30355	355	1	355	32,3	300	533	650	25 029,80
12ECSS30400	400	1	400	36,4	300	600	690	28 045,30
12ECSS30450	450	1	450	40,9	300	675	730	34 591,60
12ECSS30500	500	1	500	45,5	350	750	1100	50 770,50
12ECSS30560	560	1	560	50,9	350	840	1100	82 396,50
12ECSS30630	630	1	630	57,3	350	945	1250	105 888,30

* jiné rozměry na poptávku

FORMOVANÉ OBLOUKY

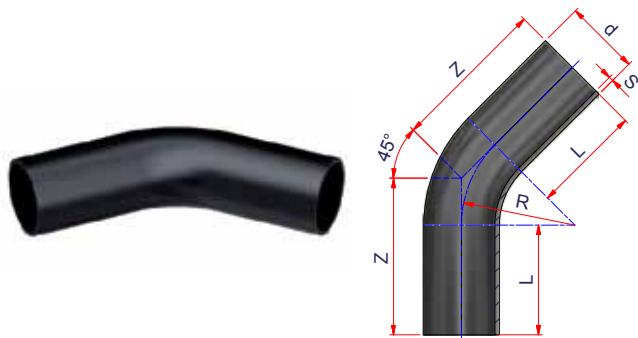

OBLOUK 45°

Rozměry L, R, Z uvedené v tabulce jsou informativní
D 710 – D 900 na vyžádání

PE100 SDR17 PN10

slevová skupina "B"

Kód	ø	Bal.	d	S	L	R	Z	Cena CZK/ks
12DCSS45110	110	1	110	6,6	150	165	340	1 804,80
12DCSS45125	125	1	125	7,4	150	188	380	2 035,30
12DCSS45140	140	1	140	8,3	150	210	405	2 347,40
12DCSS45160	160	1	160	9,5	150	240	425	2 575,80
12DCSS45180	180	1	180	10,7	150	270	460	4 620,60
12DCSS45200	200	1	200	11,9	150	300	495	4 992,30
12DCSS45225	225	1	225	13,4	150	338	525	5 907,30
12DCSS45250	250	1	250	14,8	250	375	570	7 153,10
12DCSS45280	280	1	280	16,6	250	420	550	7 912,50
12DCSS45315	315	1	315	18,7	300	473	650	10 212,40
12DCSS45355	355	1	355	21,1	300	533	650	16 134,50
12DCSS45400	400	1	400	23,7	300	600	730	22 891,20
12DCSS45450	450	1	450	26,7	300	675	830	27 558,40
12DCSS45500	500	1	500	29,7	350	750	1100	39 201,00
12DCSS45560	560	1	560	32,2	350	840	1115	63 604,00
12DCSS45630	630	1	630	37,4	350	945	1350	79 339,00

PE100 SDR11 PN16

slevová skupina "B"

Kód	ø	Bal.	d	S	L	R	Z	Cena CZK/ks
12ECSS45110	110	1	110	10	150	165	340	2 261,10
12ECSS45125	125	1	125	11,4	150	188	380	2 522,20
12ECSS45140	140	1	140	12,7	150	210	405	2 857,60
12ECSS45160	160	1	160	14,6	150	240	425	3 349,70
12ECSS45180	180	1	180	16,4	150	270	460	5 592,60
12ECSS45200	200	1	200	18,2	150	300	495	6 784,00
12ECSS45225	225	1	225	20,5	150	338	525	8 133,90
12ECSS45250	250	1	250	22,7	250	375	570	9 490,60
12ECSS45280	280	1	280	25,4	250	420	550	11 278,20
12ECSS45315	315	1	315	28,6	300	473	650	13 685,10
12ECSS45355	355	1	355	32,3	300	533	650	25 029,80
12ECSS45400	400	1	400	36,4	300	600	730	28 045,30
12ECSS45450	450	1	450	40,9	300	675	830	34 591,60
12ECSS45500	500	1	500	45,5	350	750	1100	50 770,50
12ECSS45560	560	1	560	50,9	350	840	1115	82 396,50
12ECSS45630	630	1	630	57,3	350	945	1350	105 888,30

* jiné rozměry na poptávku



FORMOVANÉ OBLOUKY

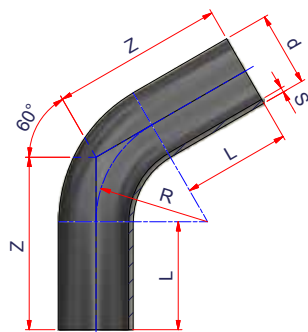

OBLOUK 60°

Rozměry L, R, Z uvedené v tabulce jsou informativní
D 710 – D 900 na vyžádání

PE100 SDR17 PN10

slevová skupina "B"

Kód	ø	Bal.	d	S	L	R	Z	Cena CZK/ks
12DCSS60110	110	1	110	6,6	160	165	255	1 804,80
12DCSS60125	125	1	125	7,4	160	187,5	268	2 035,30
12DCSS60140	140	1	140	8,3	160	210	281	2 347,40
12DCSS60160	160	1	160	9,5	160	240	298	2 575,80
12DCSS60180	180	1	180	10,7	160	270	316	4 620,60
12DCSS60200	200	1	200	11,9	160	300	333	4 992,30
12DCSS60225	225	1	225	13,4	160	337,5	355	5 907,30
12DCSS60250	250	1	250	14,8	260	375	476	7 153,10
12DCSS60280	280	1	280	16,6	260	420	502	7 912,50
12DCSS60315	315	1	315	18,7	310	472,5	583	10 212,40
12DCSS60355	355	1	355	21,1	310	532,5	617	16 134,50
12DCSS60400	400	1	400	23,7	310	600	656	22 891,20
12DCSS60450	450	1	450	26,7	310	675	700	27 558,40
12DCSS60500	500	1	500	29,7	360	750	793	39 201,00
12DCSS60560	560	1	560	32,2	400	840	885	63 604,00
12DCSS60630	630	1	630	37,4	440	945	986	79 339,00

PE100 SDR11 PN16

slevová skupina "B"

Kód	ø	Bal.	d	S	L	R	Z	Cena CZK/ks
12ECSS60110	110	1	110	10	160	165	255	2 261,10
12ECSS60125	125	1	125	11,4	160	187,5	268	2 522,20
12ECSS60140	140	1	140	12,7	160	210	281	2 857,60
12ECSS60160	160	1	160	14,6	160	240	298	3 349,70
12ECSS60180	180	1	180	16,4	160	270	316	5 592,60
12ECSS60200	200	1	200	18,2	160	300	333	6 784,00
12ECSS60225	225	1	225	20,5	160	337,5	355	8 133,90
12ECSS60250	250	1	250	22,7	260	375	476	9 490,60
12ECSS60280	280	1	280	25,4	260	420	502	11 278,20
12ECSS60315	315	1	315	28,6	310	472,5	583	13 685,10
12ECSS60355	355	1	355	32,3	310	532,5	617	25 029,80
12ECSS60400	400	1	400	36,4	310	600	656	28 045,30
12ECSS60450	450	1	450	40,9	310	675	700	34 591,60
12ECSS60500	500	1	500	45,5	360	750	793	50 770,50
12ECSS60560	560	1	560	50,9	400	840	885	82 396,50
12ECSS60630	630	1	630	57,3	440	945	986	105 888,30

* jiné rozměry na poptávku

FORMOVANÉ OBLOUKY

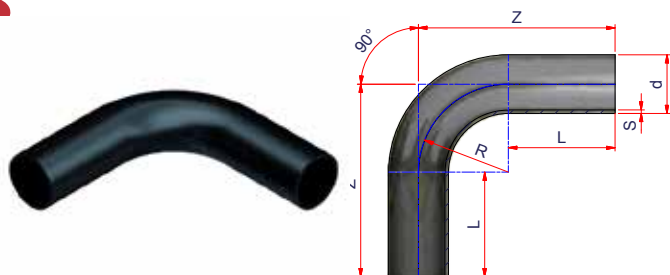

OBLOUK 90°

Rozměry L, R, Z uvedené v tabulce jsou informativní
D 710 – D 900 na vyžádání

PE100 SDR17 PN10

slevová skupina "B"

Kód	ø	Bal.	d	S	L	R	Z	Cena CZK/ks
12DCSS90110	110	1	110	6,6	160	165	325	1 842,30
12DCSS90125	125	1	125	7,4	160	187,5	347,5	2 188,60
12DCSS90140	140	1	140	8,3	160	210	370	2 619,30
12DCSS90160	160	1	160	9,5	160	240	400	2 837,40
12DCSS90180	180	1	180	10,7	160	270	430	4 523,00
12DCSS90200	200	1	200	11,9	160	300	460	5 607,40
12DCSS90225	225	1	225	13,4	160	337,5	497,5	6 450,40
12DCSS90250	250	1	250	14,8	260	375	635	8 088,60
12DCSS90280	280	1	280	16,6	260	420	680	9 120,20
12DCSS90315	315	1	315	18,7	310	472,5	782,5	11 908,40
12DCSS90355	355	1	355	21,1	310	532,5	842,5	17 520,10
12DCSS90400	400	1	400	23,7	310	600	910	25 398,90
12DCSS90450	450	1	450	26,7	310	675	985	31 833,20
12DCSS90500	500	1	500	29,7	360	750	1100	45 321,90
12DCSS90560	560	1	560	32,2	400	840	1240	77 665,90
12DCSS90630	630	1	630	37,4	440	945	1385	96 872,50

PE100 SDR11 PN16

slevová skupina "B"

Kód	ø	Bal.	d	S	L	R	Z	Cena CZK/ks
12ECSS90110	110	1	110	10	160	165	325	2 362,10
12ECSS90125	125	1	125	11,4	160	187,5	347,5	2 717,70
12ECSS90140	140	1	140	12,7	160	210	370	3 121,00
12ECSS90160	160	1	160	14,6	160	240	400	3 731,70
12ECSS90180	180	1	180	16,4	160	270	430	6 188,90
12ECSS90200	200	1	200	18,2	160	300	460	7 467,00
12ECSS90225	225	1	225	20,5	160	337,5	497,5	8 906,50
12ECSS90250	250	1	250	22,7	260	375	635	10 820,60
12ECSS90280	280	1	280	25,4	260	420	680	13 167,10
12ECSS90315	315	1	315	28,6	310	472,5	782,5	16 342,90
12ECSS90355	355	1	355	32,3	310	532,5	842,5	26 034,70
12ECSS90400	400	1	400	36,4	310	600	910	31 394,70
12ECSS90450	450	1	450	40,9	310	675	985	38 817,20
12ECSS90500	500	1	500	45,5	360	750	1100	58 149,40
12ECSS90560	560	1	560	50,9	400	840	1240	100 604,20
12ECSS90630	630	1	630	57,3	440	945	1385	129 292,30

* jiné rozměry na poptávku



PŘECHODKY ZÁVITOVÉ PE/MOSAZ

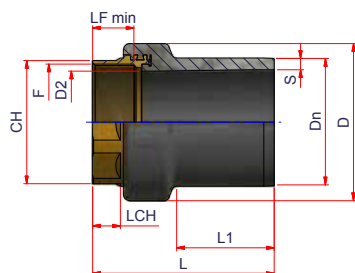

**PŘECHODKA PE/MOSAZ S VNITŘNÍM ZÁVITEM
ERFF**

PE100 SDR11 PN16

slevová skupina "A"

Kód	ø	Bal.	Váha kg/ks	Dn	S	L1	D2	F	LF min	L	D	CH	LCH	Cena CZK/ks
12ERFF2012	20x1/2"	50	0,100	20	3	44	13	1/2"	17	84	37	25	11	376,40
12ERFF2534	25x3/4"	32	0,122	25	3	44	18	3/4"	18	86	41	30	12	376,40
12ERFF321	32x1"	30	0,187	32	3	47	24	1"	21	91	50	38	13	502,80
12ERFF401	40x1"	25	0,206	40	3,7	53	24	1"	21	95	50	38	13	502,80
12ERFF40114	40x1 1/4"	15	0,293	40	3,7	53	31	1 1/4"	21,4	100	64	46	15	691,80
12ERFF50112	50x1 1/2"	10	0,410	50	4,6	61	38	1 1/2"	19	108	70	55	15	837,90
12ERFF632	63x2"	6	0,550	63	5,8	69	49	2"	23,7	122	84	65	20	1 005,50
12ERFF75212	75x2 1/2"	9	0,830	75	6,8	76	60	2 1/2"	30,2	138	107	80	25	1 759,70
12ERFF903	90x3"	2	1,350	90	8,2	87	71	3"	33,3	153	119	95	24	2 178,80
12ERFF1104	110x4"	2	2,050	110	10	85	90	4"	39,3	165	152	120	30	2 513,10
12ERFF1254	125x4"	2	2,100	125	11,4	95	99	4"	39,3	177	153	120	30	2 765,10

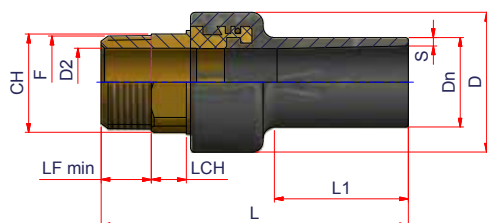

**PŘECHODKA PE/MOSAZ S VNĚJŠÍM ZÁVITEM
ERFM**

PE100 SDR11 PN16

slevová skupina "A"

Kód	ø	Bal.	Váha kg/ks	Dn	S	L1	D2	F	LF min	L	D	CH	Lch	Cena CZK/ks
12ERFM2012	20x1/2"	40	0,120	20	3	44	13	1/2"	13,2	100	36	22	11	376,40
12ERFM2534	25x3/4"	40	0,170	25	3	44	18	3/4"	14,5	103	41	27	12	376,40
12ERFM3234	32x3/4"	25	0,176	32	3	47	18	3/4"	14,5	103	41	27	12	376,40
12ERFM321	32x1"	25	0,265	32	3	47	24	1"	16,8	110	50	34	13	502,80
12ERFM401	40x1"	25	0,260	40	3,7	54	24	1"	16,8	115	50	34	13	502,80
12ERFM40114	40x1 1/4"	15	0,383	40	3,7	53	31	1 1/4"	19,1	124	63	42	15	691,80
12ERFM50112	50x1 1/2"	12	0,500	50	4,6	61	38	1 1/2"	19,1	131	70	50	15	837,90
12ERFM502	50x 2"	6	0,733	50	4,6	61	38	2"	23,4	140	83	60	18	1 005,50
12ERFM632	63x2"	9	0,750	63	5,8	69	49	2"	23,4	147	83	60	18	1 005,50
12ERFM75212	75x2 1/2"	9	1,278	75	6,8	76	60	2 1/2"	26,7	163	107	80	20	1 759,70
12ERFM903	90x3"	2	1,800	90	8,2	87	71	3"	29,8	183	118	90	23	2 178,80
12ERFM1104	110x4"	2	3,000	110	10	85	90	4"	35,8	202	153	115	30	2 513,10
12ERFM1254	125x4"	2	3,000	125	11,4	95	99	4"	35,8	214	153	115	30	2 765,10

PŘECHODKY ZEMNÍ

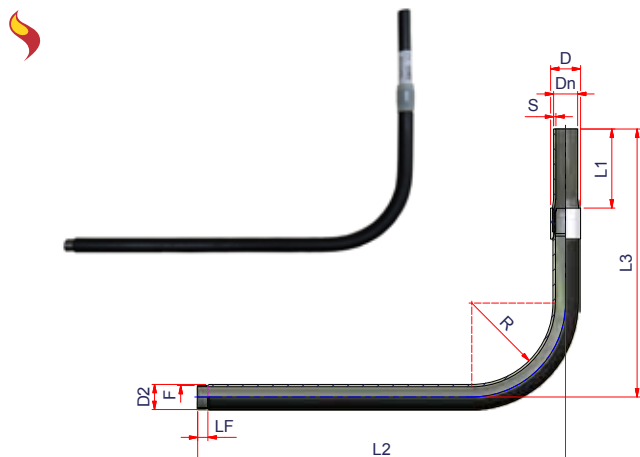

ZEMNÍ PŘECHODKA PE/OCEL 90° OBLOUKOVÁ ERTCF

Galvanizovaná zevnitř.

PE vnější opláštění

Při instalaci není potřebný RTG svar!

PE100 SDR11 PN16

slevová skupina "A"

Kód	ø	Bal.	Váha kg/ks	Dn	S	L1	F	LF	D2	L2	L3	R	D	Cena CZK/ks
12ERTCFZ025 *	25x3/4"	36	1,730	25	3	165	3/4"	14,5	30	700	500	150	32,3	1 599,90
12ERTCFZ032 *	32x1"	24	2,100	32	3	165	1"	16,8	37	700	500	150	40	1 774,70
12ERTCFZ040 *	40x1 1/4"	16	3,500	40	3,7	165	1 1/4"	19,1	45,6	700	500	150	50	2 072,30
12ERTCFZ050 *	50x1 1/2"	56	4,200	50	4,6	165	1 1/2"	19,1	52,6	770	500	170	63	2 666,50
12ERTCFZ063	63x2"	28	7,150	63	5,8	190	2"	23,4	64	770	700	260	73	3 229,30
12ERTCFZ075	75 x 2 1/2"	1	8,500	75	6,8	190	2 1/2"	26,7	80	750	700	300	88	7 516,50
12ERTCFZ090	90 x 3"	1	11,500	90	8,2	190	3"	29,8	93	700	750	300	107	10 460,50

PŘECHODKY ZEMNÍ

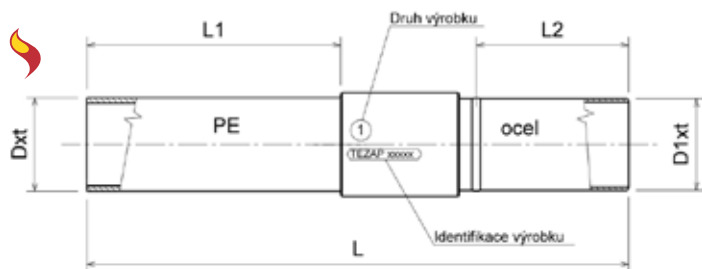

ZEMNÍ PŘECHODKA PE/OCEL



PE100 SDR11 PN16 KRÁTKÁ

slevová skupina "F"

Kód	ø	Bal.	Váha kg/ks	D x t (mm)	D1 x t (mm)	L	L1	L2	Cena CZK/ks
100200	25	1	0,5	25x3	26,9x2,65	435	165	200	513,90
100202	32	1	0,8	32x3	33,7x3,25	435	165	200	518,80
100204	40	1	1	40x3,7	42,4x3,25	435	165	200	585,40
100206	50	1	1,5	50x4,6	48,3x3,25	435	165	200	807,40
100208	63	1	2,2	63x5,8	60,3x3,65	435	165	200	925,50

PE100 SDR17 PN10 DLOUHÁ

slevová skupina "F"

Kód	ø	Bal.	Váha kg/ks	D x t (mm)	D1 x t (mm)	L	L1	L2	Cena CZK/ks
100211	90	1	5,7	90x5,2	89x4	640	300	200	2 126,70
100213	110	1	8	110x6,3	108x4	640	300	200	2 568,60
100217	160	1	9,5	160x9,1	159x4,5	640	300	200	4 072,60
100223	225	1	24	225x12,8	219x6,3	640	300	200	6 748,00
100227	315	1	56	315x17,9	324x8	640	300	200	33 115,80

* dimenze 125, 180, 250, 280, 355, 400, 450, 500, 560 a 630 se vyrábějí na zakázku, cena a dostupnost na poptávku

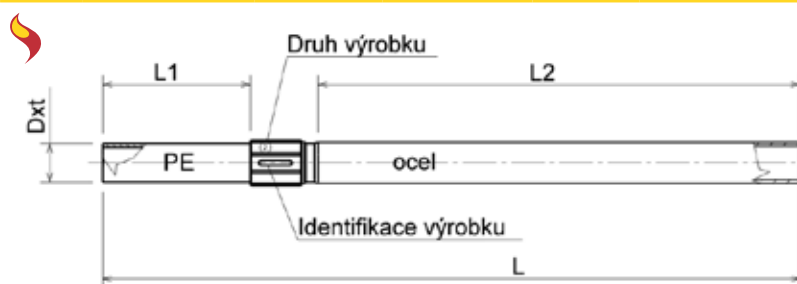

ZEMNÍ PŘECHODKA PE/OCEL



PE100 SDR11 PN16 PRODLOUŽENÁ

slevová skupina "F"

Kód	ø	Bal.	Váha kg/ks	D x t (mm)	D1 x t (mm)	L	L1	L2	Cena CZK/ks
100201	25	1	1,1	25x3	26,9x2,65	735	165	500	544,50
100203	32	1	1,7	32x3	33,7x3,25	735	165	500	583,30
100205	40	1	2	40x3,7	42,4x3,25	735	165	500	675,00
100207	50	1	2,7	50x4,6	48,3x3,25	735	165	500	977,30
100209	63	1	3,9	63x5,8	60,3x3,65	735	165	500	1 206,50



VŠEOBECNÉ OBCHODNÍ PODMÍNKY

VŠEOBECNÉ OBCHODNÍ PODMÍNKY JSOU UVEDENY NA NAŠICH
WEBOVÝCH STRÁNKÁCH

WWW.GAWAPLAST.CZ, WWW.GAWAPLAST.SK

KONTAKTY

Gawaplast Slovakia, s.r.o.

Sídlo společnosti

Záruby 1

831 01 Bratislava

IČO: 35 896 051

IČ DPH: SK2021862150

Provozovna a sklady

Priemyselná ulica

900 27 Bernolákovo

Jednatel:

Ing. Michal Kurčík

+421 903 228 860

m.kurcik@gawaplast.sk

Obchodní oddělení – Česká republika

Bc. Veronika Málková

+421 948 245 588

malkova@gawaplast.sk

Obchodní oddělení – Slovenská republika

Mgr. Ľuboš Packo

+421 903 708 454

packo@gawaplast.sk

Ing. Jakub Paták

+421 948 068 686

patak@gawaplast.sk

Technické oddělení

Miloš Hladký

+421 903 807 456

obchod.technik@gawaplast.sk

Objednávky a expedice

Lenka Candráková

+421 903 272 202

candrakova@gawaplast.sk

Sklad, servis svařovací techniky

Štefan Mesároš

+421 903 228 847

Sekretariát, fakturace

+421 903 257 251

agenda@gawaplast.sk



GAWAPLAST

SLOVAKIA



Gawaplast Slovakia, s.r.o.
Priemyselná ulica
900 27 Bernolákovo
IČO: 35 896 051
DIČ: 2021862150

email: gawa@gawaplast.cz
Mob.: +421 948 245 588
www.gawaplast.cz

NUPI INDUSTRIE ITALIANE S.P.A.
Busto Arsizio | Italia
Address Via Stefano Ferrario n. 8, Z.I.
Sud-Ovest - 21052 Busto Arsizio (VA)
Italia Phone: +39.0331.344211

